



Flamco



Flamcomat & Flamcomat Starter

ENG Installation and operating instruction



English (ENG) Table of contents

1. Liability	6
2. Warranty	6
3. Copyright	6
4. General safety instructions	6
4.1 Warning symbols in this manual	6
4.2 Purpose and use of this manual	7
4.3 Qualifications required, assumptions	7
4.4 Staff qualification	7
4.5 Appropriate use	8
4.6 Incoming goods	8
4.7 Transportation, storage, unpacking	8
4.8 Operations room	8
4.9 Noise reduction	9
4.10 EMERGENCY-STOP / EMERGENCY-OFF	9
4.11 Personal protective equipment (PPE)	9
4.12 Exceeding permitted pressure / temperature levels	9
4.13 System water	9
4.14 Safeguards	9
4.15 External forces	10
4.16 Inspection prior to commissioning, maintenance and re-inspection	10
4.17 Electrical equipment inspections, routine inspection	10
4.18 Maintenance and repairs	11
4.19 Obvious misuse	11
4.20 Other hazards	11
5. Product description	12
5.1 Operating principle	12
5.2 Markings	13
5.3 Type key Pump control unit	15
5.4 Type key Controller unit	15
5.5 Component parts, equipment	16
6. Assembly	22
6.1 Setup	22
6.2 Vessel connection	22
6.3 Top-up connection	23
6.4 Drain connection	23
6.5 System connection	23
6.6 Electrical Installation	24
7. Commissioning	25
7.1 Initial commissioning	25
7.2 Commissioning, volume level and operating temperature	26
7.3 Overview menu options	27
7.4 Sleep-interval settings of de-aeration function	28
7.5 Clarification of menu icons	28
7.6 Operation menu, configuration variants	29
7.7 Top-up, operation with the water treatment module	30
7.8 Malfunction messages	30
7.9 Restarting	34
8. Maintenance	35
8.1 Vessel draining/refilling	35
9. Decommissioning, dismantling	36
Appendix 1. Technical data, information	37
Appendix 2. Technical data, specifications, hydraulic equipment	39
Appendix 3. Technical data, information, electrical equipment	42
Appendix 4. Declaration of Conformity	44



1. Liability

All technical specifications, data and instructions for executable actions and actions that must be executed contained herein are correct at time of publication. This information is the result of our current findings and experience to the best of our knowledge. We reserve the right to make technical changes subject to the future development of the Flamco product referred to in this publication. Hence no rights may be derived from technical data, descriptions and illustrations. Technical pictures, drawings and graphs do not necessarily correspond to the actual assemblies or parts as delivered. Drawings and pictures are not to scale and contain symbols for simplification.

2. Warranty

You can find the corresponding specifications in our General Terms and Conditions.

3. Copyright

This manual must be used confidentially. It may be circulated among authorised personnel only. It must not be given to third parties. All documentation is protected by copyright. Distribution or other forms of reproduction of documents, even extracts, exploitation or notification of the contents hereof is not permitted, where not otherwise specified. Infringements are liable to prosecution and payment of compensation. We reserve the right to exercise all intellectual property rights.

4. General safety instructions

Disregard or lack of attention to the information and measures in this manual may pose a hazard to people, animals, the environment and tangible assets. Failure to observe the safety regulations and the neglect of other safety measures may lead to the lapse of liability for damages in the event of damage or loss.

Definitions

- **Operator:** A natural person or legal entity who is the owner of the product and uses the aforementioned product, or is nominated to use it, under the terms of a contractual agreement.
- **Principal:** The legally and commercially responsible party in the execution of construction projects. Legally and commercially liable client in the commission of building projects.
- **Responsible person:** The representative appointed to act by the main contractor or operator.
- **Qualified person (QP):** Any person whose professional training, experience and recent professional activity gives them the requisite professional knowledge. This implies that said person has knowledge derived from relevant national and internal safety regulations.

4.1 Warning symbols in this manual



Warning against hazardous electric current.

Disregarding this could put lives at risk, cause fires or trigger accidents, lead to component overload and damage, or prevent functionality.



Warning against the implications of errors and incorrect set-up conditions.

Disregarding this could lead to serious personal injury, to component overload and damage, or prevent functionality.



Caution! Dangerously high temperatures.

Failure to observe this caution may result in burns to the skin.



You are advised to wear eye protection.

Failure to observe this advice may result in eye injury.



Caution about transporting heavy objects.

Failure to observe this caution may endanger the safety of people in the immediate vicinity of the load.

CAUTION
Heavy load
use forklift

4.2 Purpose and use of this manual

The following pages list the information, specifications, measures and technical data that allow the relevant personnel to use this product safely and for the intended purpose.

Responsible persons or those engaged by them carrying out the required services must read this manual attentively and understand it.

Such services include:

storage, transportation, installation, electrical installation, commissioning and re-starting, operation, maintenance, inspection, repair and dismantling.

Where the product is to be used in plants/facilities which do not comply with harmonised European regulations and relevant technical rules and guidelines of professional associations for this field of application, the present document is purely for informative and reference purposes.

As this unit may be subject to unlimited inspection at all times, this manual must be kept in the immediate vicinity of the installed unit, at least within the confines of the operations room.

4.3 Qualifications required, assumptions

All personnel must have the relevant qualifications to carry out the required services, and be physically and psychologically capable. The area of responsibility, competence and supervision of personnel is the duty of the Operator.

Required service	Professional group example	Relevant qualifications example
Storage, transportation	Logistics, transport, warehousing	Transport and warehousing specialist
Assembly, disassembly, repairs, maintenance. Re-commissioning after adding or changing components. Inspection.	Installation and building services	HVAC specialist.
First commissioning of configured control unit (generic), re-commissioning after power cut, operation (work on the terminal and SPC control unit)		People with operations room clearance with knowledge gleaned from this guide.
Electrical installation	Electrical engineering	Specialist in electrical engineering/ installation
Initial and re-inspection of electrical systems		Qualified person (QP) with certification in Electrical Engineering
Inspection before commissioning and re-inspection of pressure equipment	Installation and building services engineering performed in the context of technical inspection.	Qualified Person (QP)

4.4 Staff qualification

Operating instructions are transferred by Flamco representatives or others assigned by them during delivery negotiations or on demand.

Training for the required services, installation, dismantling, commissioning, operation, inspection, maintenance and repair are part of the training / further education for service engineers of the Flamco branch offices or named service contractors.

These training courses cover information on required installation conditions, but not their implementation.

On-site services include transportation, the preparation of an operations room with the requisite foundation engineering to accommodate the system, and the requisite hydraulic and electrical connections, the electrical installation for the power source of the expansion automat and installation of the signal leads for the IT equipment.



4.5 Appropriate use

Sealed water-based heating and cooling systems in which temperature-induced changes in the volume of the system water (the heat transferring agent) can be absorbed and the required operating pressure is governed by a separate expansion automat.

The water-based heating systems are subject to EN 12828. For temperatures above 105 °C or system capacities over 1 MW, additional rules and regulations may apply. The Principal / Operator will need to consult with a notified body on additional safety measures.

Use in similar systems (e.g. heat transfer systems for process industry or technologically conditioned heat) may require special measures. Please note that the Flamcomat Starter must not be used in systems with mostly stainless steel piping and not in combination with a vacuum degasser. The complementary documents must be studied.

4.6 Incoming goods

The items delivered must be compared against the items listed on the shipping note and inspected for conformity. Unpacking, installation and commissioning may be started only once the product has been checked to conform with the intended use as stated in the order process and contract. In particular, exceeding the permissible operating or design parameters may lead to malfunctioning, component damage and personal injury.

If not in line with conformity or if the delivery is incorrect in another way, the product must not be used.



4.7 Transportation, storage, unpacking

The equipment is delivered in packaging units in accordance with the contract specifications or the specifications required for certain modes of transport and climate zones. These units meet at least the requirements set out in the Flamco B.V. packaging directives. In accordance with these directives, expansion vessels must be transported horizontally and pump units upright; each packaged on throw-away pallets. If the packaging is suitable for use with hoisting gear, this will be indicated at the designated hoisting points.

Important note: Transport the packed goods as close as possible to the envisaged set-up location and make sure there is a horizontal, solid surface on which the goods can stand.



Note! Take all necessary precautions to ensure that the expansion vessel cannot topple over or wobble once it has been unpacked and removed from the pallet.



Suitable lifting lugs are provided for lifting and moving suspended empty vessels prior to installation. Such devices (lifting lugs) must be used in tandem; avoid side-pulling.

Once it has been removed from the pallet and the packaging, the unit must be transferred by pulling it over suitable surfaces. Use methods that prevent uncontrolled falling, sliding or tipping over. The lifting lugs on the pump unit are designed so the unit can be lifted vertically. They may not be subjected to any lateral force.

The goods may also be warehoused in their packaging. Once it has been removed from its packaging, the equipment must be put in position, observing standard safety procedures. Do not stack the equipment.

Use only permitted lifting gear and safe tools and wear the required personal protective equipment.

4.8 Operations room

Definition: room which meets the applicable European regulations, European and harmonised standards and relevant technical rules and guidelines of the professional associations for this field of application. For the use of the expansion automat as prescribed in this manual these rooms generally contain equipment for thermal generation and distribution, water heating/cooling and top-up, power source and distribution, such as measuring, control engineering, control technology and IT.

Access for unqualified and untrained persons must be restricted or forbidden.

The set-up location of the expansion automat must ensure that operation, service, maintenance, inspection, repair, installation and dismantling can be carried out unhindered and without danger. The floor of the set-up location for the expansion automat must be such that stability is guaranteed and maintained. Bear in mind that the maximum possible forces can be exerted from the net mass including the water volume. If stability cannot be guaranteed, there is a danger that the vessel will tip over or move and, as a consequence in addition to functional defects may lead to personal injury.

The ambient atmosphere must be free from conductive gases, high concentrations of dust and aggressive vapours. There is the risk of explosion if any combustible gases are present.

In case of function-driven opening of the drain valve on the backflow preventer (optional top-up) or triggering of the relief valve to prevent overloading of the vessel, as well as for potential overflow at the connection in a case of vessel diaphragm damage to compensate for atmospheric pressure, the top-up or process water is drained. Depending on the process, the water temperature can rise to 70 °C and, in the case of improper operation exceed 70 °C. This presents a danger of personal injury through burns and/or scalding.

It is important to ensure that this water can be drained safely, and - to prevent water damage - that there is a safe drain or water collector in the immediate vicinity of the appropriate equipment (groundwater protection: observe additives!).

Flooded equipment must not be operated. If electrical equipment short circuits, persons or other beings in the water will be electrocuted. Furthermore, there is a danger of malfunction and partial or irreparable damage to individual components due to water saturation and corrosion.

4.9 Noise reduction

Installations should be constructed with noise-reduction measures in mind. Mechanical vibrations of the assembly (Module framework, pipework) in particular can be dampened by using insulation between contact surfaces.

4.10 EMERGENCY-STOP / EMERGENCY-OFF

To conform with directive 2006/42/EG an EMERGENCY-STOP facility is made available by the main power switch on the control unit. This switch separates the phases and neutrals. When additional security measures with EMERGENCY-OFF devices are required according to the design and operation of the heat generator, these are to be installed on-site.

4.11 Personal protective equipment (PPE)

PPE must be used when carrying out potentially dangerous work and other activities (e.g. welding), in order to prevent or minimise the risk of personal injury if other measures cannot be taken. These must comply with the requirements specified by the main contractor or operator of the operations room or the site in question.

If no requirements are specified, to operate the automat no PPE is required. Minimum requirements are well-fitting clothing and sturdy, closed and skidproof footwear.

Other services require the protective clothing and equipment necessary for the activity in question (e.g. transport and assembly: rugged, close-fitting work clothing, foot protectors [safety shoes with toe caps], head protection [safety helmet], hand protectors [protective gloves]; maintenance, repair and overhaul: rugged, close-fitting work clothing, foot protectors, hand protectors, eye/face protector [safety goggles]).

4.12 Exceeding permitted pressure / temperature levels

Equipment used in combination with the expansion automat must guarantee that the permitted operating temperature and the permitted medium temperature (heat transfer medium) cannot be exceeded. Excess pressure and temperature may lead to component overload, irreparable damage to components, loss of function and, as a result, to severe personal injury and damage to property. Regular checks/inspections of these safeguards must be carried out. Service logs must be kept.

4.13 System water

Water which is non-flammable, does not contain solids or long-fibre components and does not present a danger to operations due to its contents, and will not affect or damage the water bearing components (e.g.: pressurised components, the diaphragm, vessel connection) of the expansion automat. Also observe: VDI 2035 - avoidance of damage to warm water heating equipment.

System water containing components are pipelines, hoses connected to the vessel, devices and system connections including valves and fittings, and their casings, sensors, pumps, the vessel itself and the vessel diaphragm. Operation with improper media can lead to impaired function, damage to components and, as a consequence, to serious personal injury and damage.

4.14 Safeguards

The equipment supplied is equipped with the required safety devices. To test their effectiveness or restore the set-up conditions, the equipment must first be taken out of service. Taking the system out of service implies that power should be cut and hydraulic connections blocked, to prevent accidental or unintentional re-connection.

Mechanical hazards:

The fan cover on the pump protects users from personal injury caused by moving parts. Before switching the unit on, make sure that the cover is suitable for this purpose and properly secured.



Electrical hazards:

The protection class of electrically operated components prevents personal injury by electrocution, which can be fatal. The protection class is usually IP54 (5: Dust protected, protected against ingress with a wire; 4: protected against splashing water). The control unit cover, the cover of the pump feed, the threaded cable glands and the valve connector plugs must be inspected for effectiveness prior to commissioning. The installed pressure and volume sensors are operated with protective extra-low voltage.

Avoid welding work on additional equipment which is electrically connected to the control unit. Stray welding current or an improper earth connection could lead to the danger of fire and damage to parts of the unit (e.g. the control unit).

4.15 External forces

Avoid any additional forces (e.g.: forces caused by heat expansion, flow oscillations or dead weights on the flow and return lines). These can lead to damage / leaks in water-bearing pipework, loss of stability of the appliance and furthermore to failure connected with substantial material damage and personal injury.

4.16 Inspection prior to commissioning, maintenance and re-inspection

They guarantee operational safety and its observance in line with applicable European regulations, European and harmonised standards and additional national regulations of the EU member states for this field of application. The required inspections must be arranged by the owner or operator; an inspection and maintenance log book for scheduling and traceability of measures taken must be kept.

Tests in line with the German ordinance on operational safety (BetrSichV, June 2015):

Pressure equipment, vessels (§14; 15)					
Category [see appendix II of Directive 2014/68/EU, diagram 2)	Nominal vessel capacity [litres]	Inspection prior to commissioning [§14] inspector	Re-inspection [§15 (5)]		
			Timeframe, maximum period [a] / inspector		
			External inspection	Internal inspection	Strength inspection
II	200- 300 / 3 bar	Qualified Person (QP)	Maximum period not defined. The maximum interval must be established by the Operator on the basis of information provided by the manufacturer coupled with practical experience and chamber load. The inspection may be carried out by a Qualified person.		
III	400- 10000 / 3 bar		No longer applicable [§15 (6)]	5 / QP	10 / QP
				[§15 (10)] In the case of internal inspections the visual inspection may be replaced by similar procedures and in the case of strength tests the static pressure test may be replaced by similar, non-destructive procedures if said tests would not otherwise be possible due to system design or not significant due to the system mode of operation.	
Maintenance of equipment, interior and strength inspection, see maintenance, Ch. 8.					

In other Member States of the EC, the required tests for the pressure equipment in line with directive 2014/68/EU as defined in the national rules must be performed.

4.17 Electrical equipment inspections, routine inspection

Without prejudice to the considerations of the insurer/Operator, it is recommended that the electrical equipment of the Flamcomat be inspected and documented together with the heating/cooling unit no less than every 18 months (see also DIN EN 60204-1 2007).

4.18 Maintenance and repairs

These services may only be carried out when the system is shut down or if the expansion automat is not required. The pressurisation equipment must be taken out of service and guarded against unintentional re-starting until the maintenance work is finished. Note that the safety circuits and data transmissions made whilst shutting down could trigger the safety chain or lead to false information. Existing instructions for the heating or cooling unit as a whole must be observed. To stop hydraulic components, block the relevant sections and drain them using the safe system water drains through the available drain connections, and relieve the pressure.



Caution: The maximum system water temperature in conducting components (vessel, pumps, casings, hoses, pipelines, peripheral equipment) may reach 70 °C and, in the case of improper operation, may exceed that. This presents a danger of burns and/or scalding.



The maximum pressure of system water in conducting components may be equal to the maximum set pressure for the applicable safety valve. Vessel, nominal pressure 3 bar, safety valve max. 3 bar; pump unit nominal pressure 6; 10 or 16 bar: Safety valve max. 6; 10 or 16 bar. Use of eye/face protectors is required if the eyes or face could be injured by flying parts or spraying fluids.

To stop electrical equipment (control unit, pumps, valves, peripheral equipment), cut power to the control unit. The power supply must remain off for the period of the work.

It is forbidden to alter or use non-original components or replacement parts without authorisation. Such acts may result in serious personal injury and endanger operational safety. They will also render any claim for damages against product liability void.

It is recommended to contact Flamco Customer Service for carrying out these services.

4.19 Obvious misuse

- Operation at incorrect voltage and/or frequency.
- Use in inappropriate system designs.
- Use of unpermitted installation materials.

4.20 Other hazards

- Overload of construction parts by the presence of unpredictable extreme values.
- Operational continuity at risk in the case of changed, non-permissible ambient conditions.
- Operational continuity at risk in the case of safety-control parts being taken out of service or malfunctioning.



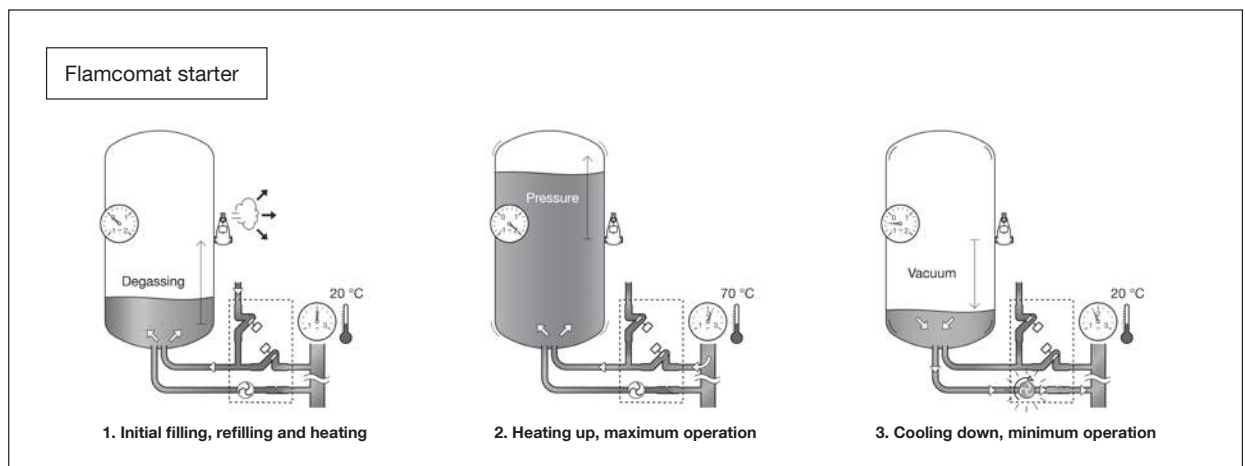
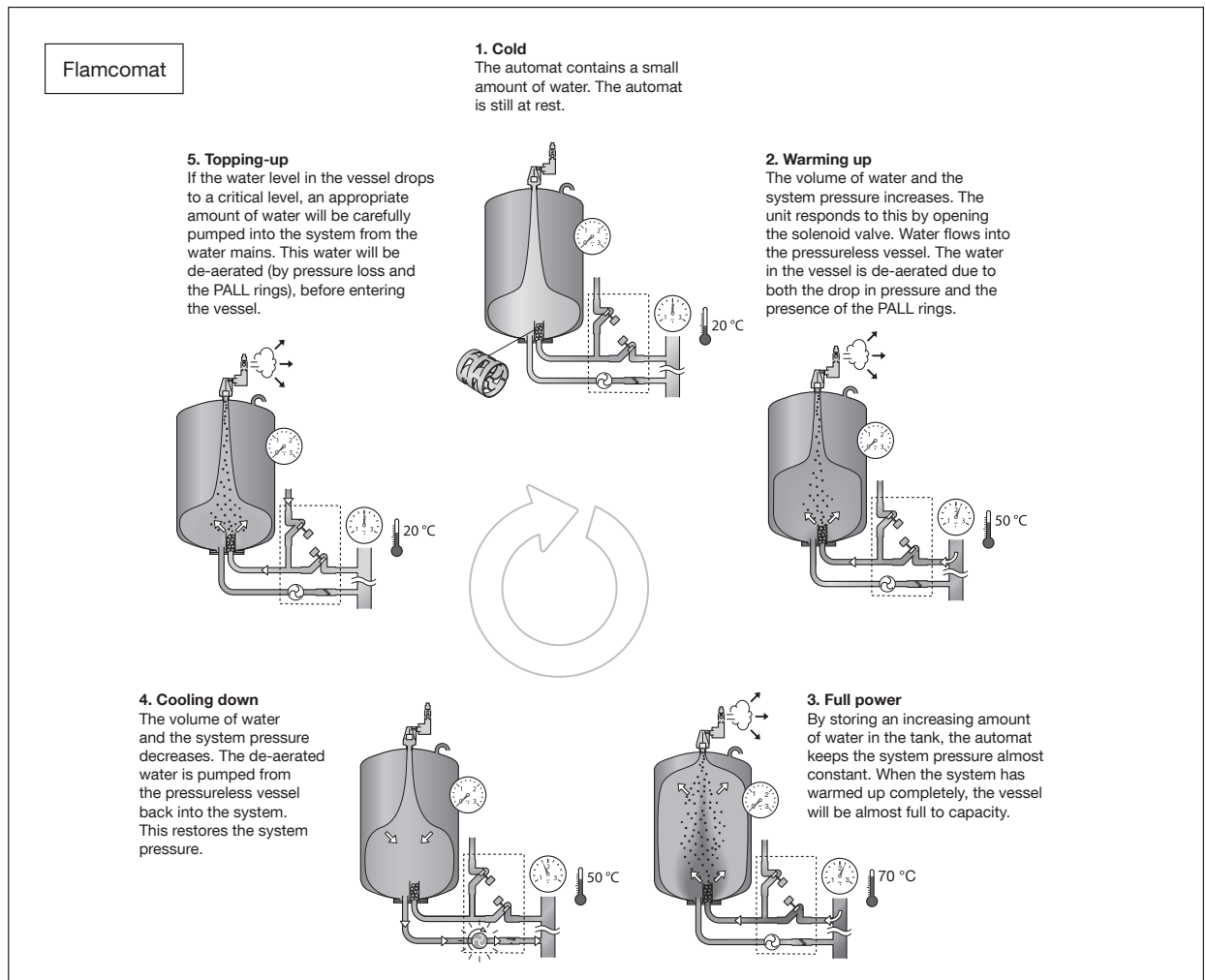
5. Product description

The contents of this manual consist of the specifications for a standard execution. Where appropriate, this includes information on options or other configurations. If optional extras are supplied, further documentation will be supplied in addition to this manual.

For installation instructions and further documentation in various languages, visit www.flamcogroup.com/manuals.

Further product information can be obtained from the respective Flamco branch office (see page 2).

5.1 Operating principle



5.2 Markings

Name plate - Vessel:

Fig. FM.002.V01.15

Name plate - Control unit:

Fig. FM.005.V01.15

System Flow:

Fig. FM.008.V01.15

System Return:

Fig. FM.009.V01.15

Name plate - Pump module:

Fig. FM.003.V01.15

Pump:

Fig. FM.010.V01.15

Valve:

Fig. FM.011.V01.15

System Flow:
module connection to return line of the heating or cooling system (volume supply)

System Return:
module connection from return line of the heating or cooling system (volume return)

Pump:
vessel connection on pump suction side (flexible connection assembly, sensor flexible connection assembly)

Valve:
vessel connection valve drain (flexible connection assembly, sensor flexible connection assembly)

Transport lock:

Fig. FM.004.V01.15

Electrical warnings:

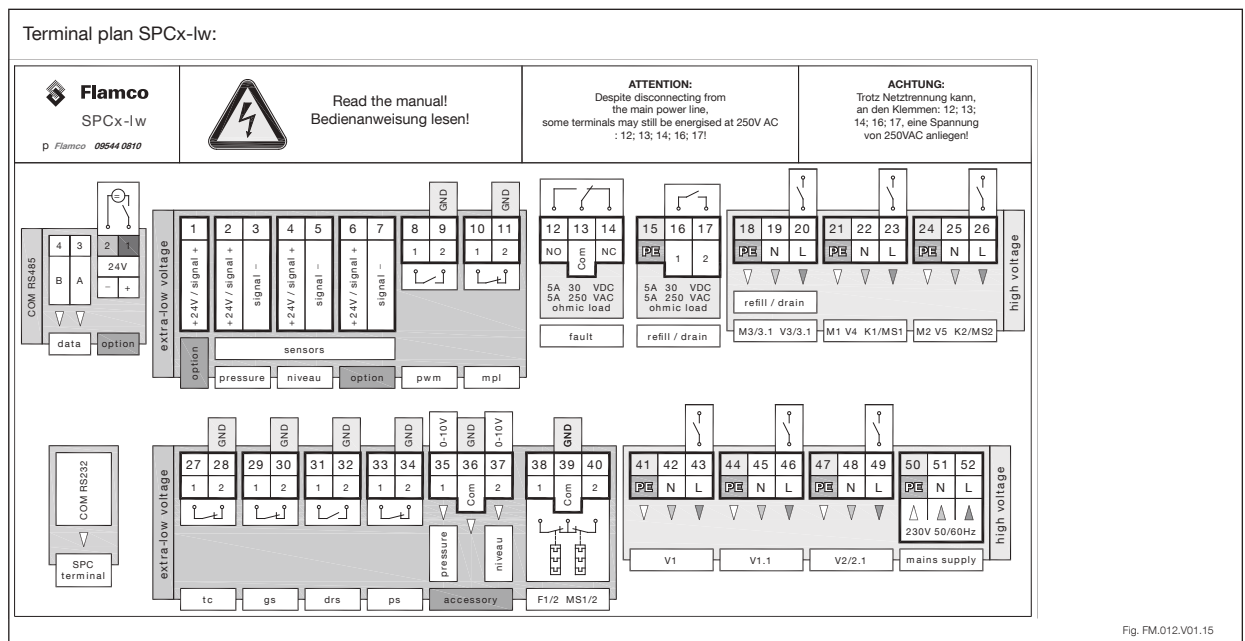
Attention, high voltage! Opening by qualified personnel only. Disconnect the unit from the power supply before opening it.

Achtung, gefährliche Spannung! Nur vom Fachpersonal zu öffnen. Vor dem Öffnen des Gerätes spannungsfrei schalten.

Service:

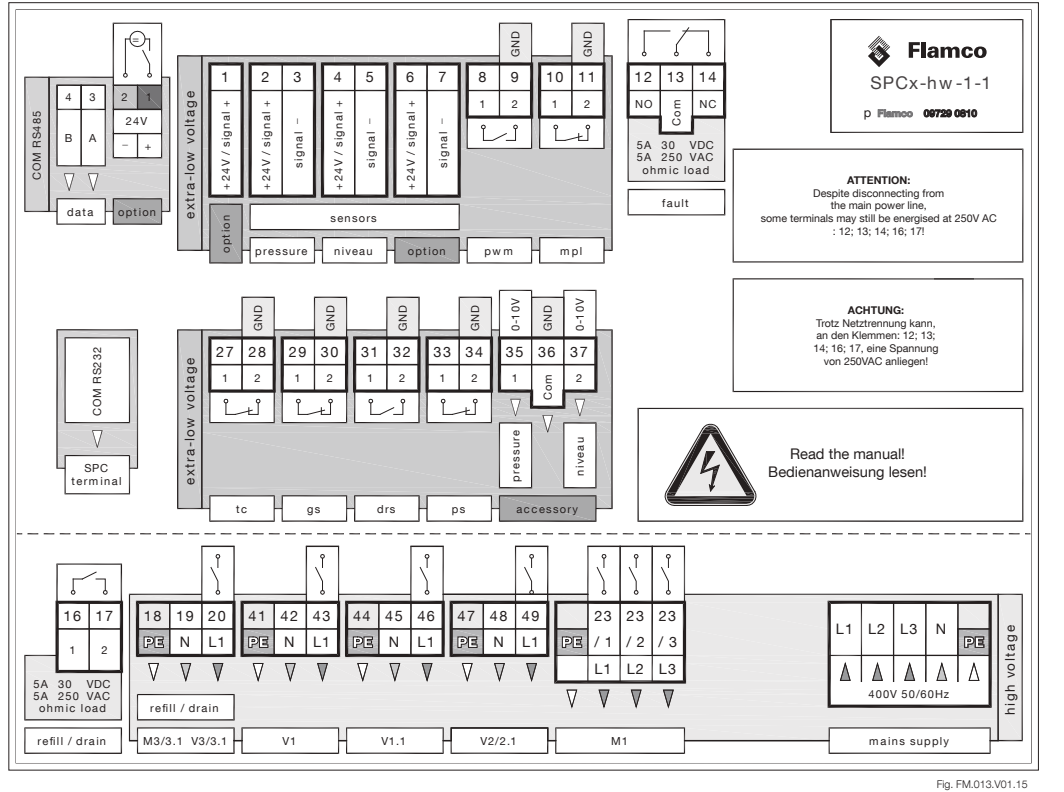
Service Nederland
Tel.: +31(0)33 299 7500
Fax.: +31(0)33 298 6445

Service Germany
Tel.: +49(0)170 630 40 34

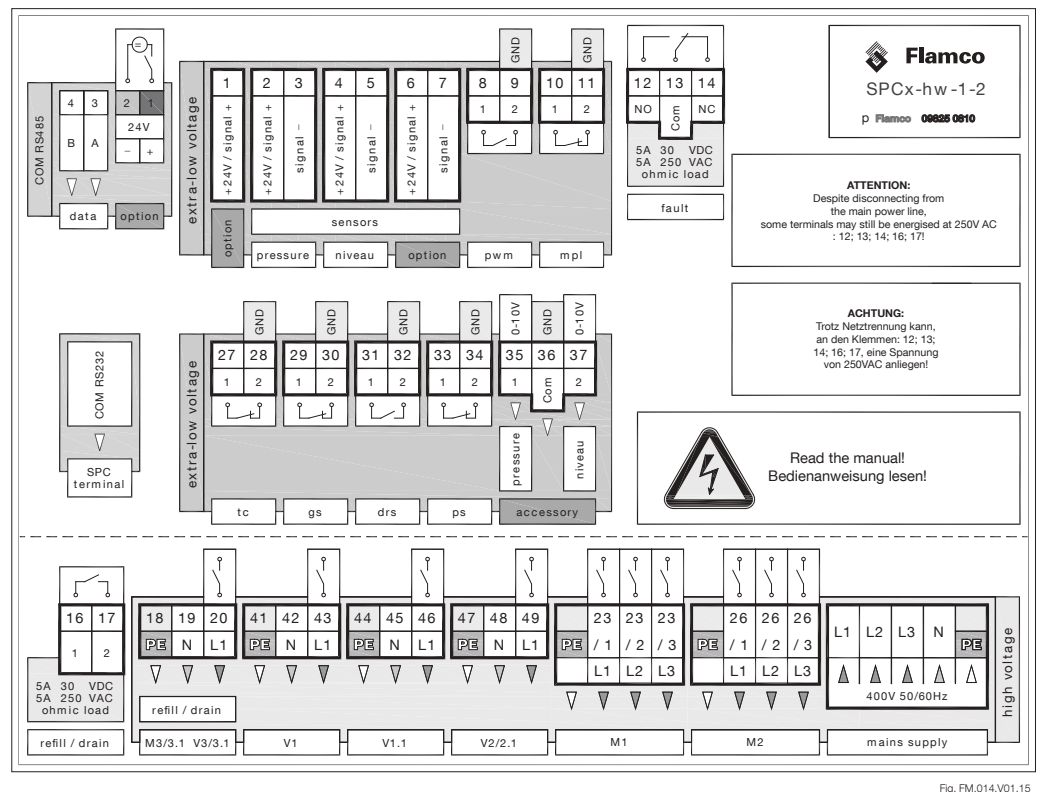




Terminal plan SPCx-hw-1-1:



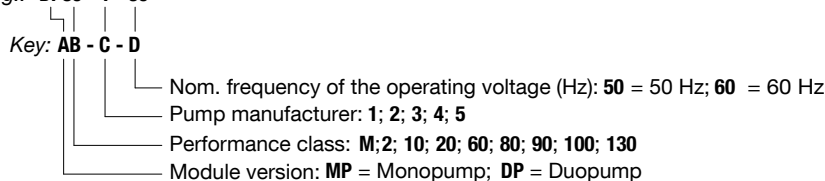
Terminal plan SPCx-hw-1-2:



Alphabetic glossary of abbreviations in terminal plan.	
Note: mentioned switch settings are in current-free, un-switched situation.	
accessory	(SPC Extension volume, pressure analog, optional)
COM	COM interface; serial port
COM	The common port
data	(Data protocol, optional)
drs	(Diaphragm rupture sensor, optional)
extra low voltage	Protective low voltage
fault	Error message, common error message Displayed switch setting is error.
F1/2 MS1/2	(Motor circuit-switch 1/2; Motor circuit-switch combination 1/2, SPCx-hw)
gs	(Gas sensor, optional Gas sensor flexible connection assembly)
high voltage	Voltage as per markings on the automat
mains supply	Power feed
mpl	(Minimum pressure limiter, optional)
M3/3.1 V3/3.1	Motor 3 (top-up, optional) / 3.1 (drainage, optional); valve 3 (top-up) / 3.1 (drainage, optional)
M1 V4 K1/MS1	Motor 2 (pressure increase); valve 5 (not applicable); switch 2 / motor circuit-switch combination 2, SPCx-hw
M2 V5 K2/MS2	Motor 2 (pressure increase); valve 5 (not applicable); switch 2 / motor circuit-switch combination 2, SPCx-hw
niveau	Level, content
ohmic load	Ohmic load, resistance
option	(not applicable)
pressure	Pressure
pwm	(Impulse water meter, optional)
ps	(Pressure switch; level switch min. level, top-up pump, optional)
refill / drain	Top-up / (drain , optional)
sensors	Sensors
tc	(Temperature switch, optional)
V1; 1.1	Valve 1; 1.1; parallel, air release valve (pressure drop)
V2	Valve 2; air release valve (pressure drop)
V2.1	Valve 2.1 (not applicable)

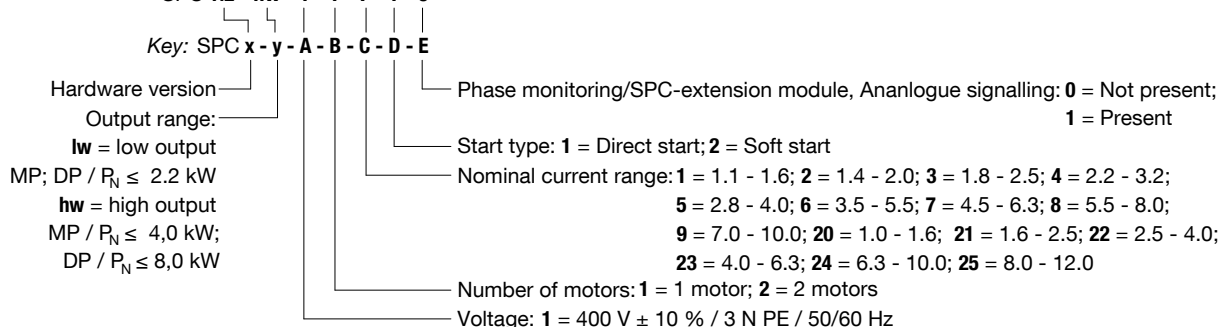
5.3 Type key Pump control unit

E.g.: **DP80 - 1 - 50**



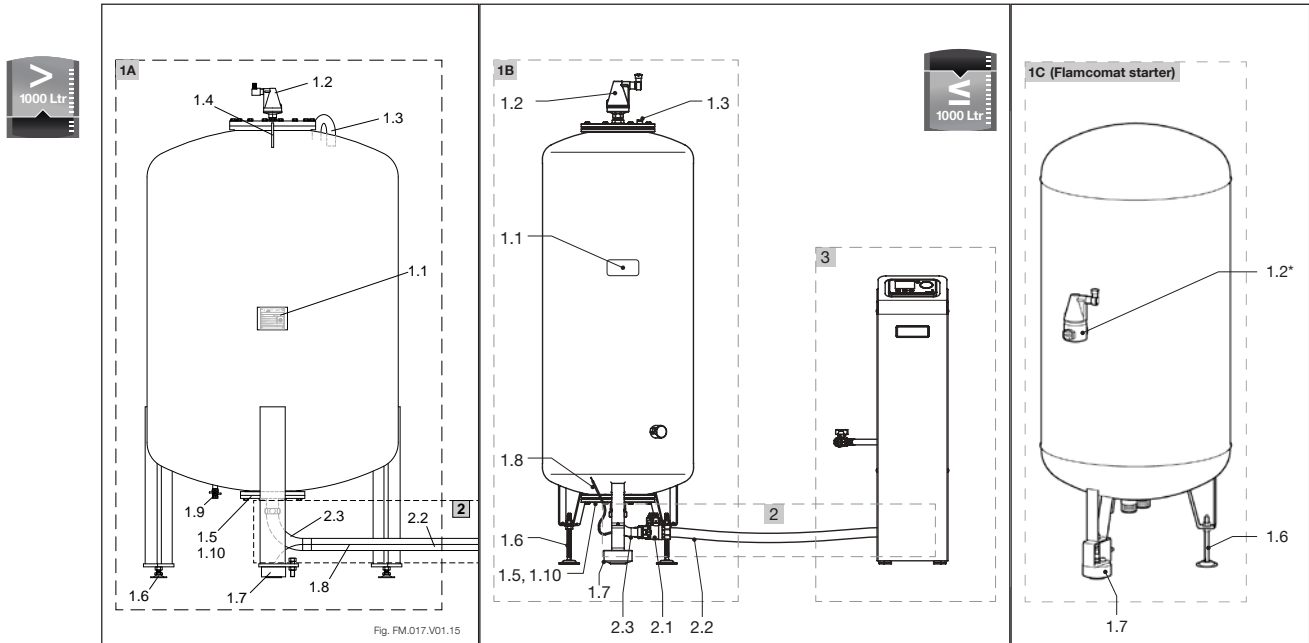
5.4 Type key Controller unit

E.g.: **SPC 1.2 - lw**
SPC 1.2 - hw - 1 - 1 - 7 - 1 - 0





5.5 Component parts, equipment



1 Basic steel vessel (1A/B with built-in, exchangeable butyl-rubber diaphragm for absorption of the expansion water under atmospheric separation conditions).

- 1.1 Name plate - Vessel:
- 1.2 Bleeder valve, float vent with air-intake preventer to dissipate extracted gases into the atmosphere
* Incl. Vacuum safety valve
- 1.3 Atmospheric pressure balancing connection Interior of vessel (space between inner vessel surface and outer diaphragm surface)
- 1.5 Flange, vessel connection with internally fitted degassing equipment, screw union, connection array valve outflow line and pump suction line, each with flat gasket (labelling)
- 1.6 Adjustable feet.
- 1.7 Capacity sensor with screw-type round plug connector to signal wire
- 1.8 Signal wire level sensor
- 1.10 Markings for pump and valve connection

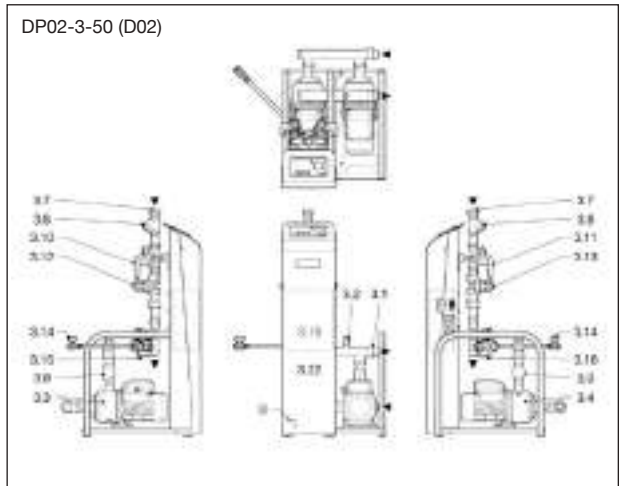
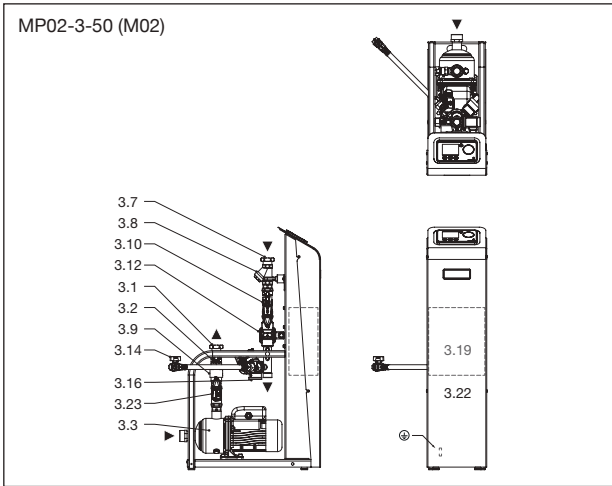
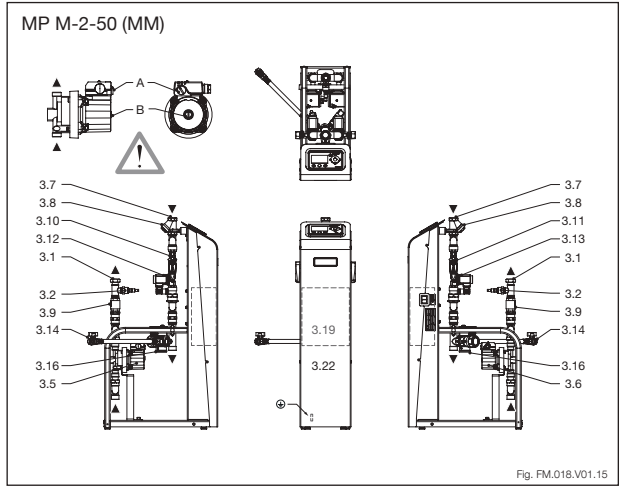
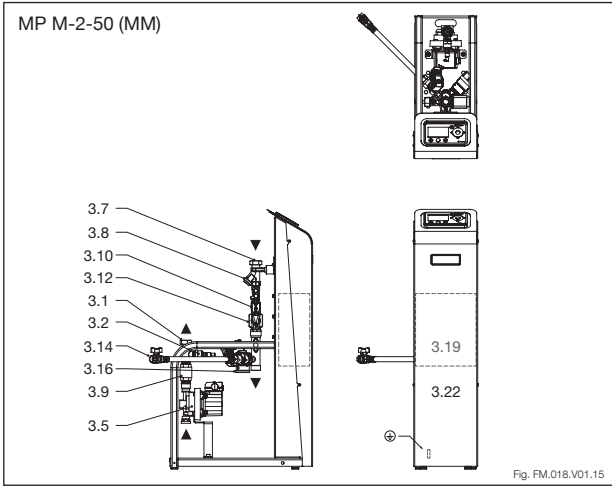
- 1.4 Lifting hook, load suspension for transport
- 1.9 Lockshield valve for condensate drainage

2 Connection assembly, pre-installed, including flat seal

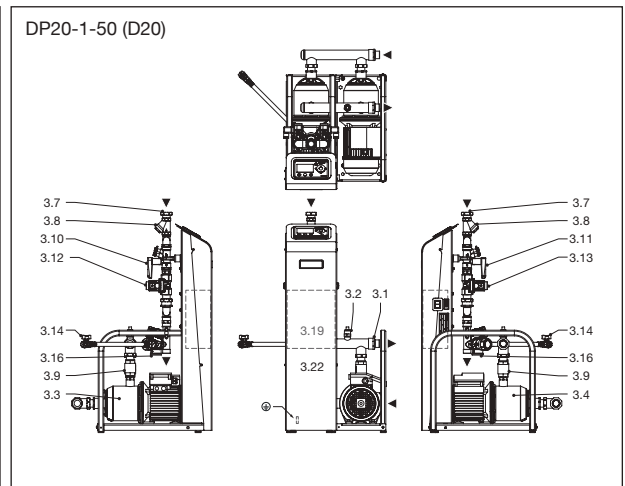
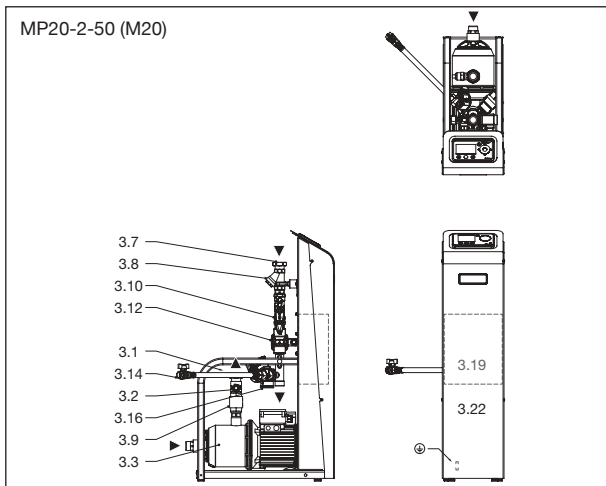
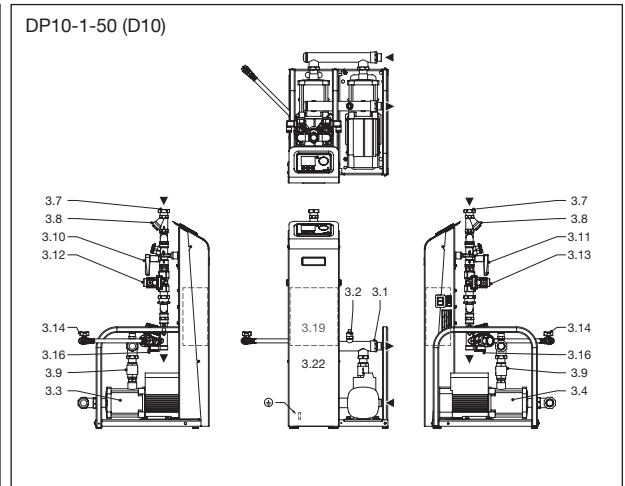
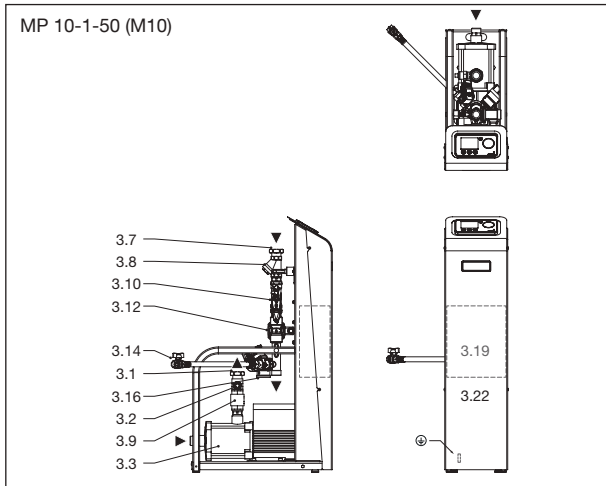
- 2.1 Self-draining lockshield valve (vessel) with flat seal, control unit port
- 2.2 Flexible pressure/suction hose
- 2.3 Pipe bend, flat sealing, vessel connector (DN32: 400 - 1000 liter, DN40: 1200 - 1600 liter.)

3 Pump module, control module, including type plate

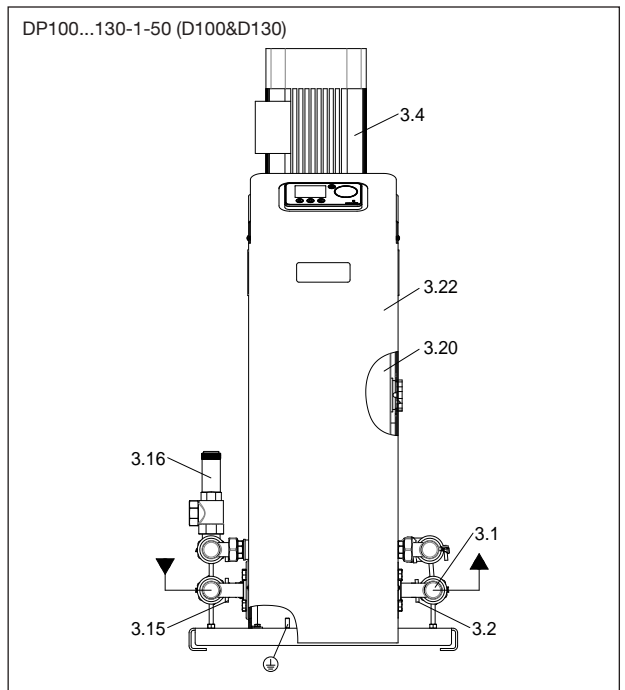
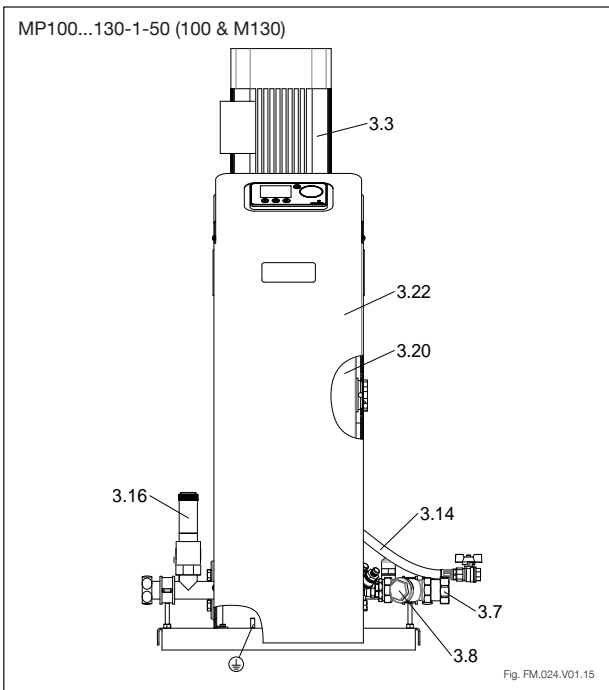
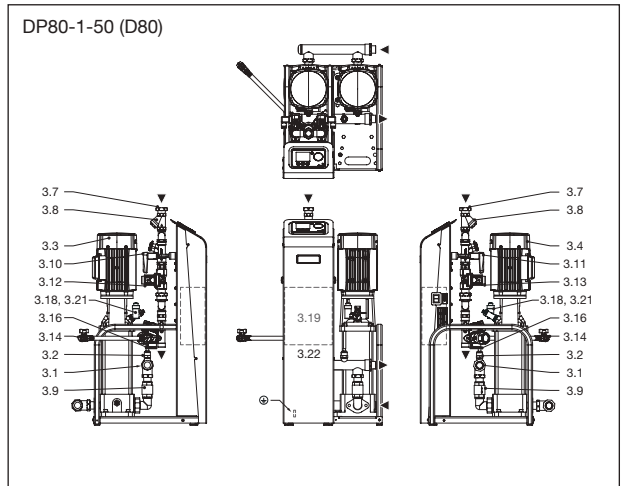
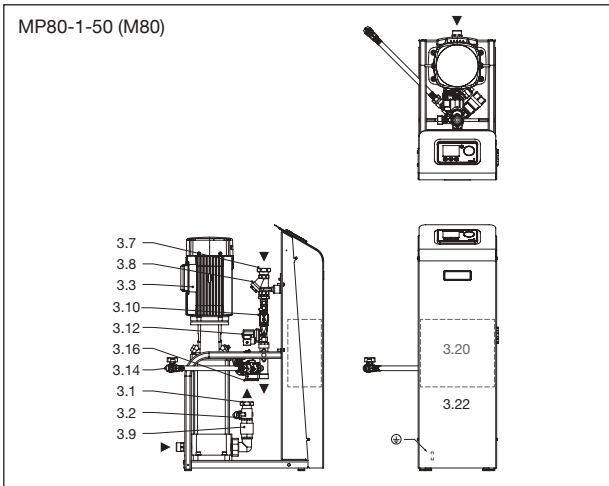
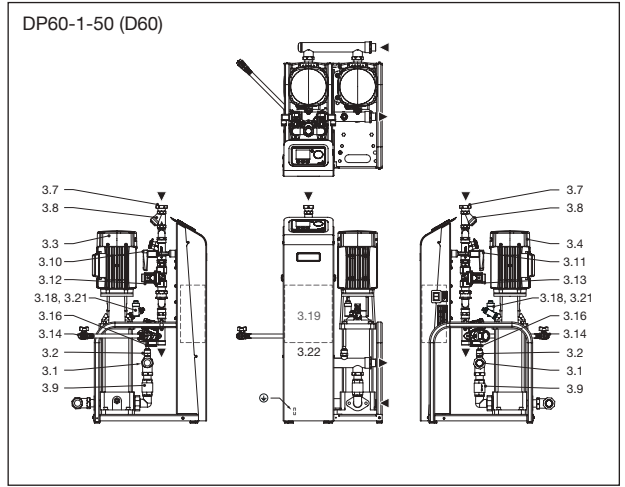
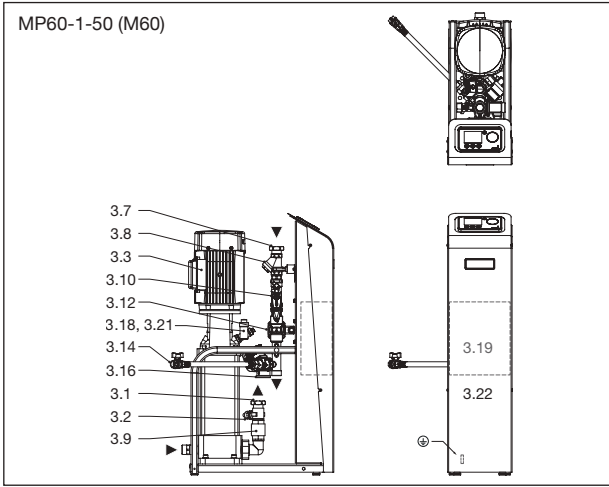
- 3.1 Pump pressure pipe, system supply (marking)
- 3.2 Pressure sensor
- 3.3 Pump 1 with manual de-aeration (hex screw with seal)
- 3.4 Pump 2 with manual de-aeration (hex screw with seal)
- 3.5 Pump 1, wet runner, self-priming
A speed select switch, *max. position!*
B Vent (slotted-head screw with seal)
- 3.6 Pump 2, wet runner, self-priming
A speed select switch, *max. position!*
B Vent (slotted-head screw with seal)
- 3.7 Valve discharge pipe, system discharge (marking)
- 3.8 Particle filter
- 3.9 Non-return valve
- 3.10 Manual regulated valve 1 (diagram)
- 3.11 Manual regulated valve 2 (diagram)
- 3.12 Solenoid valve, overflow valve no. 1
- 3.13 Solenoid valve, overflow valve no. 2
- 3.14 Top-up line, incorporating the shut-off valve (lockshield valve), flexible pressure hose, solenoid valve, top-up valve, no. 3, and check valve (optional)
- 3.16 Safety valve (*vessel*)
- 3.17 Lockshield valve system connection (optional)
- 3.18 Automatic deaerator with air-intake preventer (MP,DP60-1 -50)
- 3.19 Control unit, SPCx-lw including type plate
- 3.20 Control unit, SPCx-hw including type plate
- 3.21 Bleed pump
- 3.22 Front panel
- 3.23 Manual regulated valve 3 (diagram)



For item designations, see page 16.



For item designations, see page 16.



For item designations, see page 16.

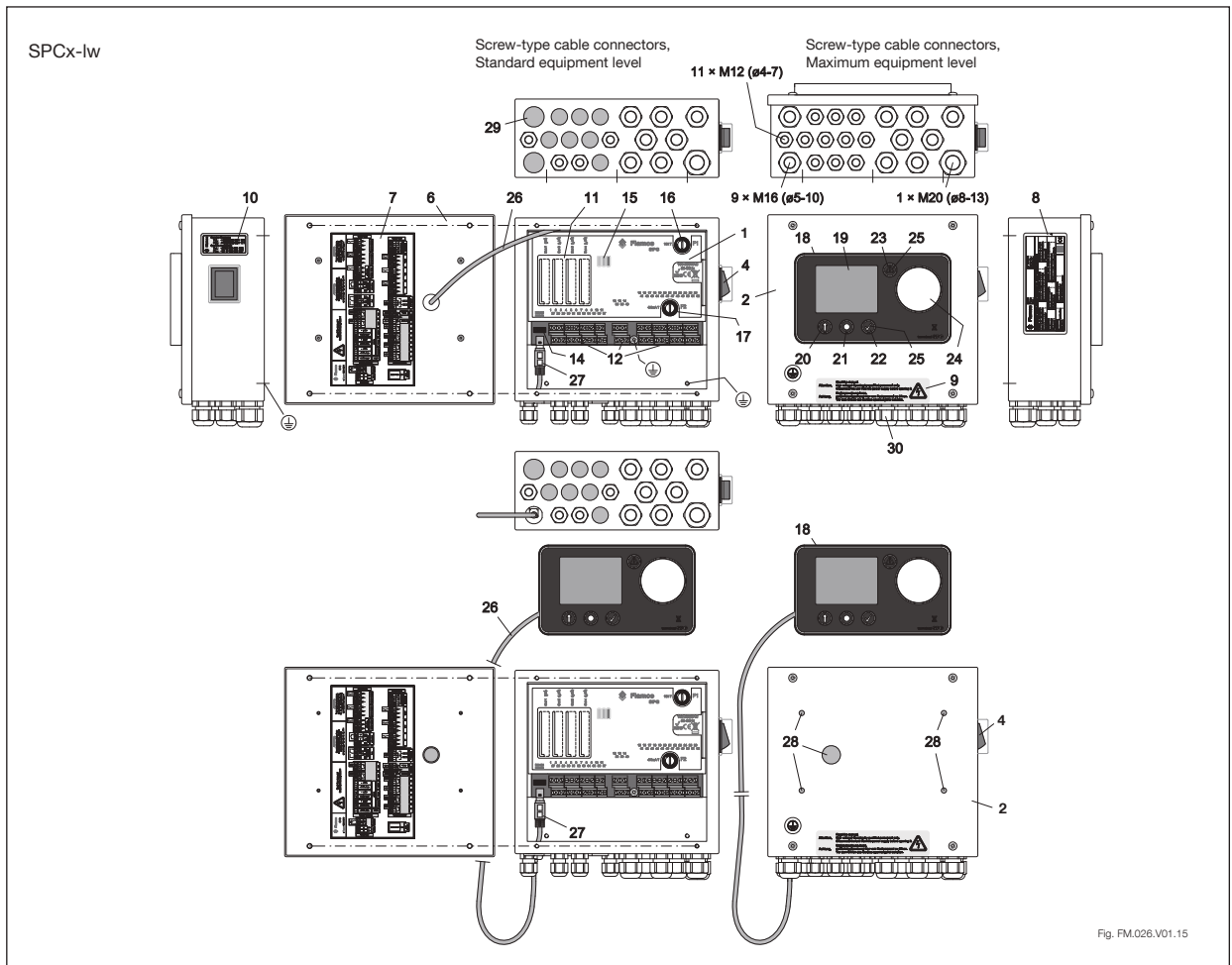


Fig. FM.026.V01.15

- | | |
|--|--|
| <ul style="list-style-type: none"> 1 Control unit SPCx 2 Control unit SPCx-lw 3 Control unit SPCx-hw 4 Main power switch L, N; On: "Red light" 5 Main power switch L1, L2, L3, N; On: "Display, Pos. 19; LED, Pos. 15 On" 6 Control unit cover open, inside view 7 Terminal port diagram (see terminal plan) 8 Control unit name plate 9 Electrical warnings 10 Service connection information 11 Slots, slot 1 ... 4 (SPC extension, option) (openings to accommodate modules via predetermined breaking points) 12 Screw terminals I/O ports (see SPCx-lw terminal plan) 13 Screw terminals I/O ports (see SPCx-hw terminal plan) 14 RS485 serial port connector (Data protocol, optional) 15 LED warning lights, back lit *
LED, yellow on: Automatic mode off; controller is in configuration mode or commissioning menu not completed.
LED, green on: The terminal is on; the SPC is connected to the SPC terminal system error, identical to pos. 23
LED, red on: | <ul style="list-style-type: none"> 16 Microfuse F1; 16A T; equipment protection 17 Microfuse F2; 400 mA T; additional equipment protection; 18 SPC Terminal (display and operating panel) 19 Graphic display with back light (dimmer in energy-saving mode) 20 Sensor button: "Back" or functions as shown in the display. 21 Sensor button, unlock the key functions for backlighting (blue). Backlighting and functional assignments also shown in the display. 22 Sensor button: "Confirmed...Enter" 23 Sensor button: "Error call" 24 Sensor slider, selector 25 Back light on when key function is ready. Also function for unlocking the buttons 26 SPC terminal feed wire 27 RS232 port, SPC terminal 28 Cap plugs, SPC terminal mounting holes 29 Plugs, location hole cable glands 30 Screw-type cable connectors 31 Motor 1 motor circuit switch combination (MP versions: SPCx-hw-1-1 and -2) 32 Motor 2 motor circuit switch combination (DP versions: SPCx-hw-1-2) |
|--|--|

* additional displays (analysis).

SPCx-hw-1-2

ENG

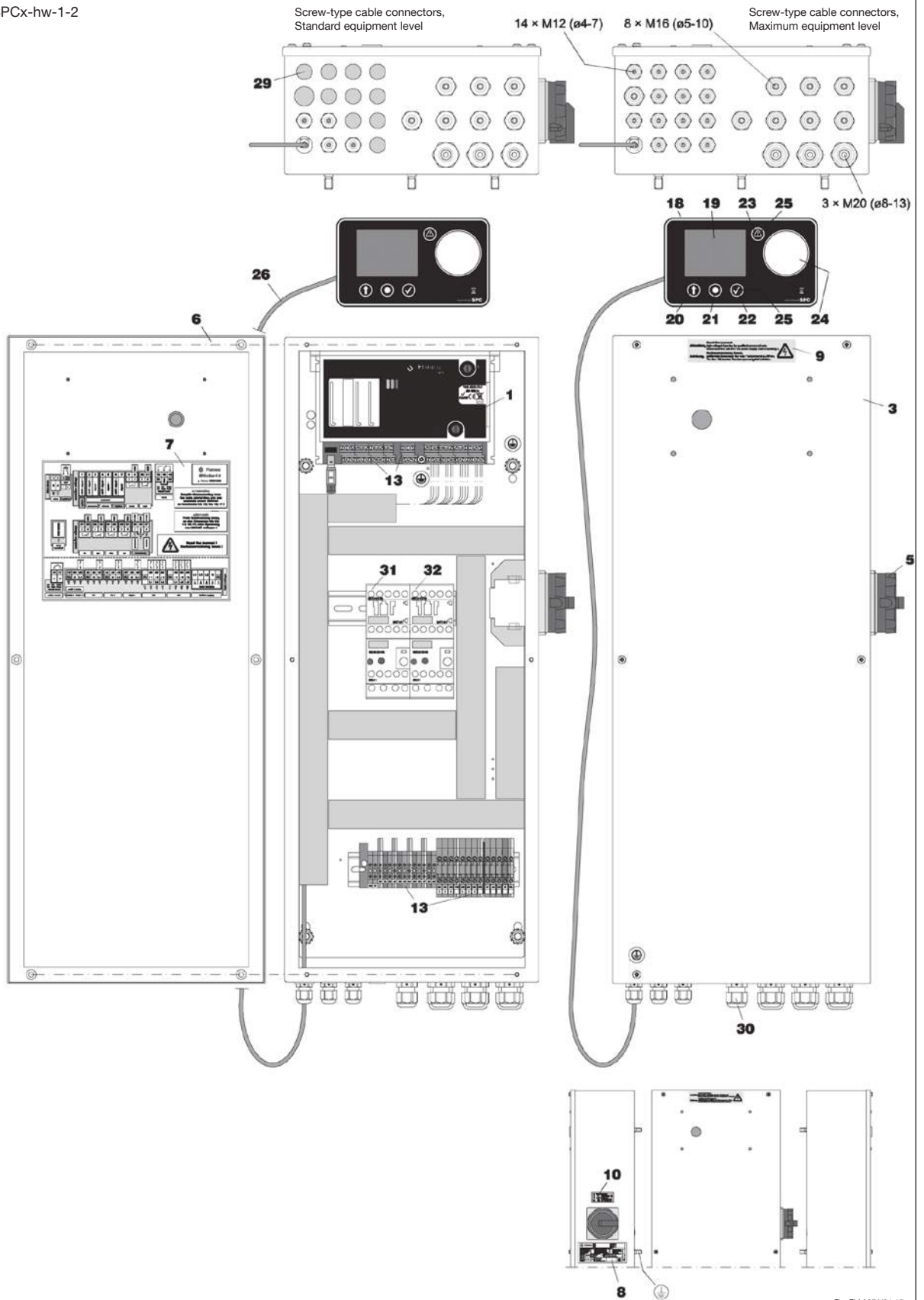


Fig. FM.027.V01.15



6. Assembly

6.1 Setup



- Fit the automatic vent (supplied separately).



Fig. FM.030.V01.15

- Remove the transport seal by the volume sensor once the basic vessel has been set up in the proposed place and no further positional changes are necessary. Avoid impact on the sensor and make sure the sensor is on a surface which does not impair the function of the sensor pressure-pad.



- Installation of the weight-capacity sensor and the adjustable feet.

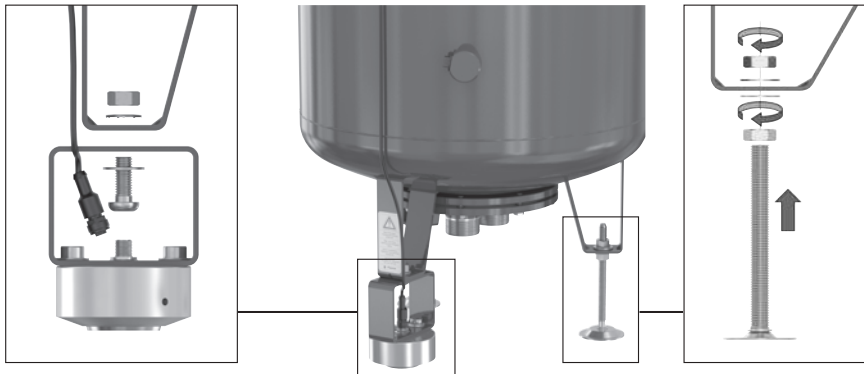


Fig. FM.031.V01.15

- Using the foot-height adjuster, adjust the vessel until it is vertical. Use two vertical magnetic spirit levels.
- Ensure that no external additional forces can be exerted on the basic vessel (e.g. tools laid on the vessel, things leaning on the sides).



Fig. FM.032.V01.15

- Do not fix the basic vessel to the ground on which it is erected (do not use any sort of fastening which can adversely affect the vessel, e.g. sinking the feet into concrete or lime, welding of the vessel or its feet, clamps and ties on the body of the structure or appurtenances).

- Place the control module, the basic vessel and the auxiliary vessel at the same height.



Fig. FM.033.V01.15

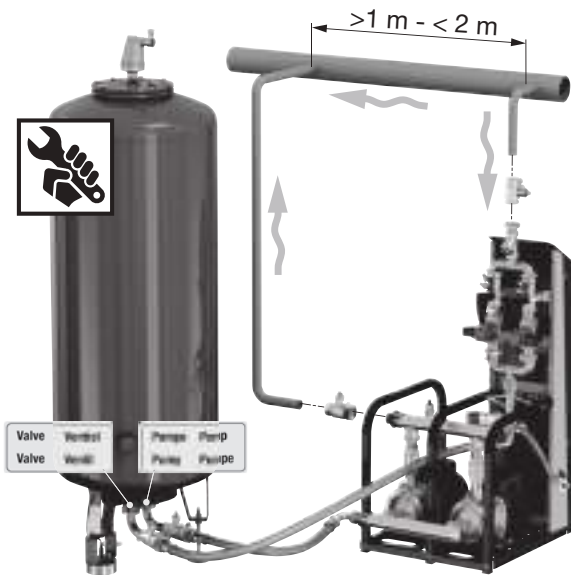
6.2 Vessel connection

The vessel connection is produced as an electric or hydraulic connection to the pump module. For the installation diagram and example installation see appendix 1. Please observe the following points prior to filling and commissioning of the pressure expansion vessels:

- Install the connection assembly between the vessel and the control module.



Caution: Ensure that the connection between the pump module and the basic vessel is made with the supplied flexible pressure hoses (connection assembly).



Take note of the labels 'pump' and 'valve' on the connections and connect up the appropriate connection from the pump module (valve) to the pump (valve) on the vessel connection.

Do not cross these connections and, if necessary, mount the vessel connection flange so as to enable parallel pipe fitting. Use the flat seals supplied.



Fig. FM.034.V01.15

- Connect the signal line via the quick-release connection to the capacity sensor. Screw this connection entirely into the connector (protection class IP67).
- Open the lockshield valve on the connection assembly between the vessel (basic vessel, intermediate vessel) and control module.

6.3 Top-up connection

The top-up connection should be connected to the control unit. Assured top-up requires an average set feed pressure of approx. 4-6 bar (max. 8 bar). High feed pressures may require devices to prevent water hammer (pressure reducing valve).

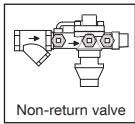


Fig. FM.035.V01.15

Appendix 1 shows the installation diagram and example installation.

Please observe the following specifications before filling and commissioning the pressure-expansion automat:

- Install the feed to the top-up hose with shut-off valve (as delivered).
- Avoid any tensile loads on the hose, bending radii of less than 50 mm and contractions.
- If the top-up feed is connected to the water main, a backflow preventer with filter must be connected in series in compliance with EN 806-4/EN 1717. Install this accessory horizontally and fit a shut-off valve before this assembly (note: clean filter regularly and change filters as and when required).



Caution: Connect the shut-off valve to the top-up intake.

6.4 Drain connection

To safely route the volume flows to be discharged at the safety valve (Pos. 3.16), backflow preventer (accessory, top-up) and the atmospheric pressure compensation connection (Pos.1.3) a drain is required in the vicinity of the Flamcomat equipment.

- Install a drain funnel and, if necessary, a drain pipe for the backflow preventer.
- When a discharge pipe is connected to the safety valve, the connection must be kept open to atmospheric pressure. An atmospheric funnel from the Flamco product catalogue can be fitted for this purpose.

6.5 System connection

The system connection should be connected to the heating or cooling system.

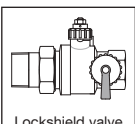


Fig. FM.036.V01.15

Appendix 1 shows the installation diagram and example installation.

Please observe the following specifications before filling and commissioning the pressure-expansion automat:

- The connection should preferably be made in the return line of the heating system. Please note that a temperature at the system connection > 70 °C (...80 °C) would exceed the permissible pump/diaphragm load and possibly lead to damage to components. (Complete insulation of the expansion pipe may increase the temperature load on the control unit and the diaphragm).
- Make sure that this connection is directly connected to the heat generator, and that there are no external hydraulic pressure influences present at the point of entrainment (e.g. hydraulic balancers, distributors).
- The flow determines how you should install the expansion lines. When fitting expansion lines to the return > 5 m in length, use pipes of at least one nominal diameter larger than that of the pump module. Avoid additional loads to the system connection of the control unit (e.g. from heat expansion, flow oscillations, dead weights).
- Equipment with flow temperatures > 100 °C must have a minimum pressure limiter fitted in the expansion line (system drain, valve drain pipework). The arrangement is contained in Appendix 1. In applications in accordance with DIN EN12828:2003 (D), this limiter is only envisaged for use if the pressure holding device does not have an automatic top-up system.



- Use sealants and pipework relevant to the installation; however, please observe at least the maximum permitted volumetric flow, pressure and temperature values for the expansion line in question (control unit/system inlet and outlet).
- Fit a non-return valve in the immediate vicinity of the system connection on the control unit that cannot be unintentionally shut off.



Caution: Close the lockshield valve at the system inlet and outlet of the control unit.

6.6 Electrical Installation

The provision of power supply, (protective) ground wire connection and line protection must be made in accordance with the regulations of the responsible power company and the applicable standards. The required information can be found on the type plate of the control unit, the terminal plan (labelling) and in Appendix 3.

The mains connection to be provided via a CEE plug/socket combination with load-switching ability. It should be a snap-on type, to avoid unintended disconnections. For units with a total rated power above 3 kW (see Appendix 3) we recommend interlocking this combination with a combined switch so that plugging or disconnecting is only possible if the switch is in the OFF position. The separator should be marked accordingly, easy to handle and placed appropriately in the vicinity of the unit.

Hint: install equipotential bonding between earth connection and equipotential bonding conductor. The minimum diameter, quality and type of the power cables should apply to the on-site applicable rules and regulations for this application. The electrical control terminals must be connected at the set-up location to the mains power supply at the relevant operating voltage.

The finished system allows the user to program the configuration and system-dependent parameters into the control unit.

7. Commissioning

7.1 Initial commissioning

- Document the commissioning procedure (actions and settings).
- Check that the installation and other actions prior to use have been carried out in full (e.g. power supply available and connected, functioning or active fuses, seal tightness of the equipment, transport protection of the volume sensor removed).



Caution: Ensure that the basic vessel is not filled until all the commissioning measures have been completed.

- Adjust the manual control valve on the pump module (see appendix 2). On the M02, the second manual control valve must be set as well.
- Fill and de-aerate the heating or cooling system (not the vessel!)
- Check the operational readiness of the top-up line.
- Open the valve at the top-up connection and the lockshield valve at the flexible connection assembly (vessel connection).
- Switch on the control unit and run the start menu procedure (Ch 7.3; overview of menu, entries; menu lines 9...9-99).
- First select the required language in point 4 of the main menu.
- Depending on the initial configuration in the start menu Point 9-5 and 9-6 will appear instead of 9-7.
- Then the Flamcomat basic vessel shall be selected based upon its nominal capacity (Ch 5.2, name-plate Vessel) and consequently the factory-, operating calibration shall be performed.
- This start-up procedure is followed by activating the top-up procedure. Once a volume level of approx. 7% has been reached (see display), switch OFF the control unit and de-aerate the pump(s) (Par. 5.5; pos. 3.5 B; 3.6 B, page 96; pos 3.20). On pumps with automatic de-aeration, these must be opened by a single turn of the red cap on these components.
- Open the cap valve on the return circuit (system flow and return) Caution, the heating system pipes may be hot.
- Seal the lockshield valves.
- The completion of all the tasks to be carried out, the review of technical data, recommendations and explanations in this manual lead to the pressure expansion automat being ready for operation.
- **SWITCH ON THE CONTROL UNIT.**

Balancing valves on the pump unit may not be closed during operation as doing so may cause severe/destructive damage to the pump unit.



7.2 Commissioning, volume level and operating temperature

Note: If a different fill level is required than the self-established minimum level after start (operational ready and installed top-up), the vessel should be filled to reflect the minimum required level needed for the actual system temperature, after completing the commissioning procedure on the control unit. For better understanding, study the diagrams below and the paragraph on maintenance, vessel draining and re-filling later in this document.

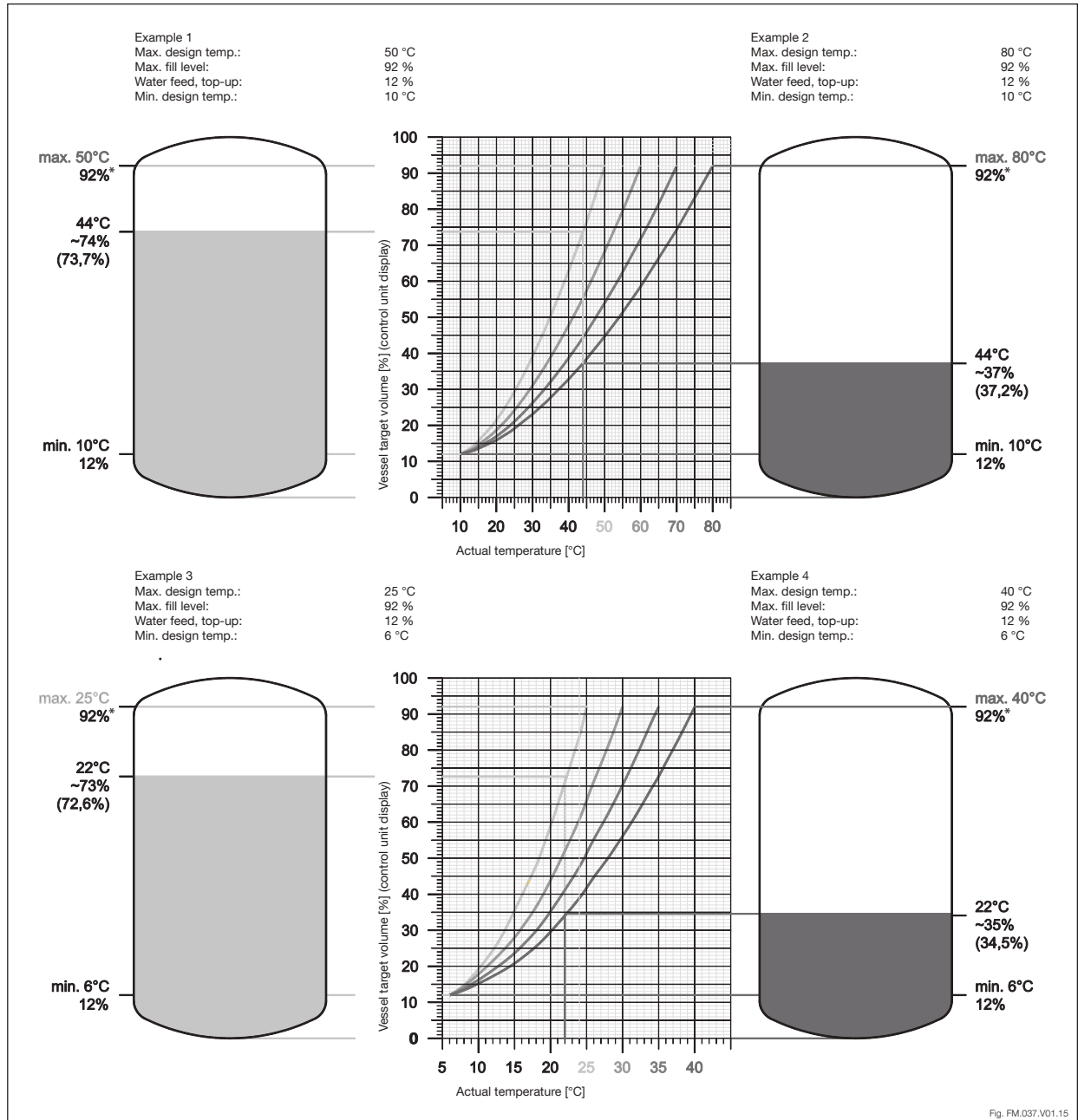
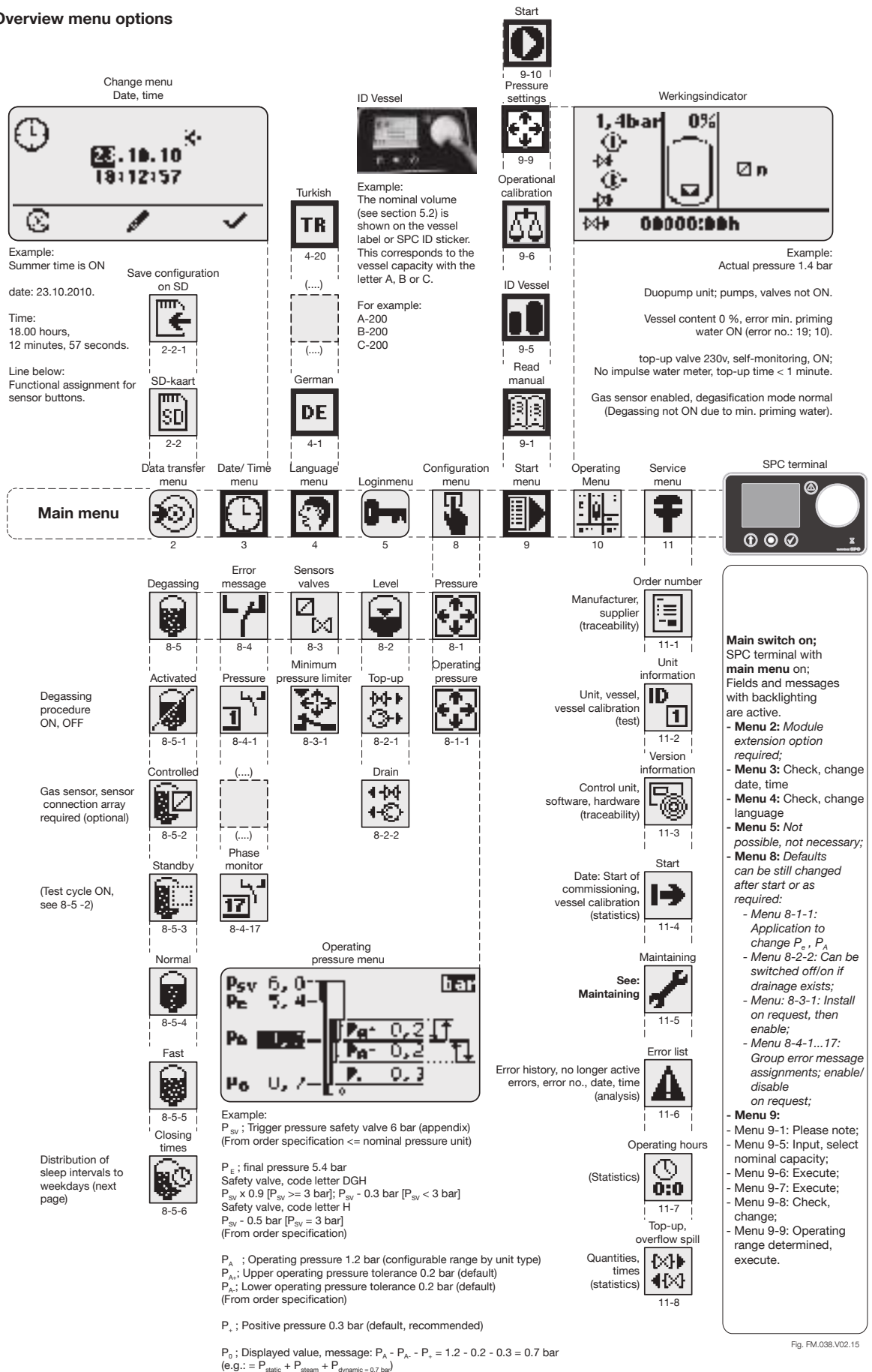


Fig. FM.037.V01.15



Note: For Flamcomat Starter vessels (reference C), handles a maximum filling level of 77%.

7.3 Overview menu options





7.4 Sleep-interval settings of de-aeration function

Example of sleep interval: 1 day with intervals 2 and 3

00:00	Blocked	10:00	Degassing	18:00	Blocked	23:59.99
-------	---------	-------	-----------	-------	---------	----------

Closing times

8-5-6

Closing interval

8-5-6-1

Interval

Monday

8-5-6-2

Interval assignment

1 2 3 4 5

00:00
08:00

8-5-6-1-1

NO.	Default, Interval	Menu
1	00:00 - 08:00	8-5-6-1-1
2	00:00 - 10:00	8-5-6-1-2
3	18:00 - 23:59.99	8-5-6-1-2
Type MPM; DPM		
4	09:30 - 23:59.99	8-5-6-1-4
4-5	00:00 - 00:00	8-5-6-1-...

Example of change menu Interval 1

1 2 3 4 5

00:00
08:00

8-5-6-2-1

Day	Default, interval assignment	Menu
1	1; 3	8-5-6-2-1...
2	1; 3	8-5-6-3-1...
3	1; 3	8-5-6-4-1...
4	1; 3	8-5-6-5-1...
5	1; 3	8-5-6-6-1...
6	2; 3	8-5-6-7-1...
Type MPM; DPM:		
4		
7	4	8-5-6-8-1...

Fig. FM.053.V01.15

7.5 Clarification of menu icons

Button functions must be unlocked (locking occurs 10 minutes after the last key press).

Memory error, loss of values (Service)

Waiting for evaluation to complete.

Values have not levelled off in vessel calibration (rule out malfunction, repeat calibration).

Input and/or output signal of the capacity sensor does not exist (check signal line, capacity sensor).

Entry confirmed

Commissioning by service required.

Entry rejected, not possible, editing limit exceeded.

Vessel calibration with value outside of the upper range (empty vessel, rule out malfunctions, align vessel, repeat calibration).

Vessel calibration with value outside of the lower range (align vessel, rule out malfunctions, repeat calibration).

Fig. FM.054.V01.15

7.6 Operation menu, configuration variants

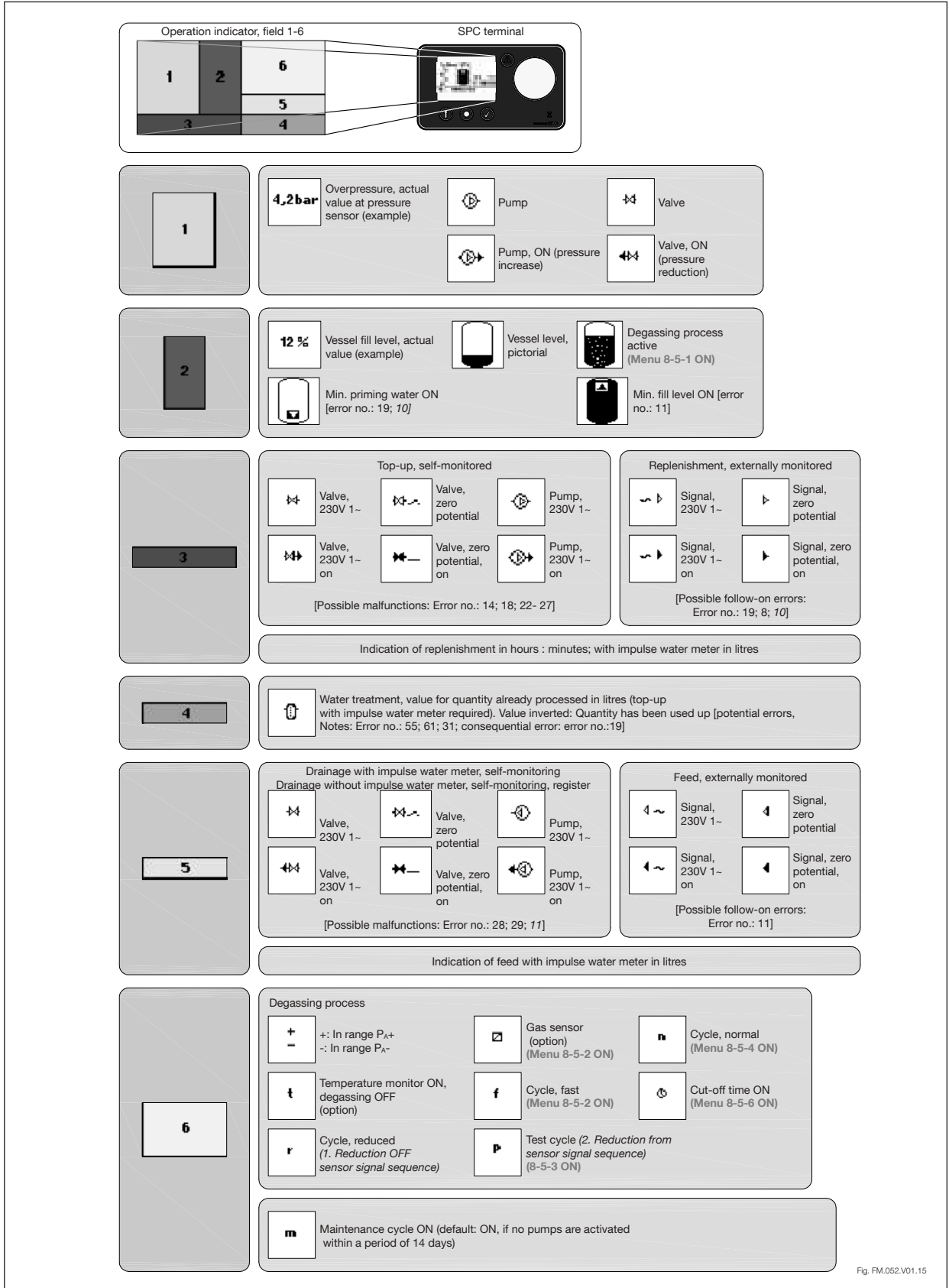


Fig. FM.052.V01.15



7.7 Top-up, operation with the water treatment module

Maintenance
11-5

Treatment quantity reset
11-5-6

Perform action

Reset the treated quantity:
Required after each change of the treatment module. Observe error message nos.: 55; 61; 31; page 28. When reset, the value in field 4 of the operating menu [10] changes from the previously processed quantity to: 00000 l

Caution:
Resetting to: 00000 l without replacing the module, and without verifying the residual capacity, leads to an unacceptable quality of the top-up water!

Top-up
8-2-1

Treatment
300 l
8-2-1-4

activate edit mode?

Changing the treatment volume
Required if the default value (300 litres) does not match the capacity of the initial module, or the preset value of the used module does not match the capacity of the module changed. (Impulse water counter standard: 10 l / Imp.)

Caution:
The use of an incorrect value can lead to unacceptable quality of the top-up water or prevent the use remaining capacities!

192
99999
00000 l
1

192
Perform action

Fig. FM.055.V01-15

7.8 Malfunction messages

Procedures and values for error identification, evaluation and output have been tried in practice, prevent secondary failures and invite user awareness. Please note that incorrect set-up conditions can lead to repeated errors and inhibit the intended use. Examples of incorrect set-up conditions are: incorrect or no longer applicable design, outdated equipment, incorrect installation and inadmissible operational parameters.

Group error message menu line no.	Error, designation cause; effect/action	Default setting	Value	Error message number
-	Voltage spike sensor (short circuit)	ON		1
-	Pressure sensor > 20 mA	ON		2
	Signal out of sensor range or short circuit, no pressure readout; lockshield valves in return connection in incorrect position / check electrical installation, threaded round connector, sensor range (4-20 mA; 16 bar), return connection, change sensor if necessary » service; Error off: self-resetting when error resolved.			
-	Pressure sensor < 4 mA	ON		3
	Signal below sensor range or not connected, no pressure readout / check electrical installation, threaded round connector, sensor range (4 -20 mA; 16 bar), change sensor if necessary » service; Error off: self-resetting when error resolved.			
-	Volume sensor > 20 mA	ON		4
	Signal out of sensor range or short circuit, no volume readout / check electrical installation, threaded round connector, sensor range (FSI 1: 150-300; 2: 400-800; 3: 1000-2000; 4: 2500-5000; 5: 6500-10000), change sensor if necessary» service; Error OFF: self-resetting when error resolved.			
-	Volume sensor < 4 mA	ON		5
	Signal out of sensor range or not connected, no volume readout/ check electrical installation, threaded round connector or sensor range; change sensor if necessary» service; Error OFF: self-resetting when error resolved.			

Group error message menu line no.	Error, designation cause; effect/action	Default setting	Value	Error message number
8-4- 1	Pressure Minimum operating pressure ON (actual pressure): Default setting has been reached or not achieved; lockshield valves in vessel or return connection in incorrect position, insufficient capacity of pumps, improper system layout, or as consequence of error no.: 10-16; 15-17; 19; 20; 22-27 /, check system lay-out, electronic installation, pumps, leak-tightness of the equipment and system and lockshield valves; insufficient capacity diagnosed » service; Error OFF: self-resetting when error resolved.	OFF	$P_A - P_{A-} - 0.3 \text{ bar}$	8
	Maximum operating pressure ON (actual pressure): Default setting has been reached or exceeded; lockshield valves in return connection in incorrect position, improper system layout, or as consequence of error no. : 11; 20 / check system lay-out, electronic installation, valve 1; 2 , particle filter, return connection, lockshield valve; if necessary » service; Error OFF: self-resetting when error resolved.		$P_A + P_{A+} + 0.3 \text{ bar}$	9
8-4- 2	Level vessel Minimum fill level vessel ON: Default setting has been reached or not achieved; pump motor 1; 2 is turned off; with top-up feature installed, top-up is ON (rising level starting at 0%); see error no.: Error OFF: self-resetting when error resolved.	OFF	5 %	10
	Minimum priming water ON: Default setting has been reached or not achieved; pump motor 1; 2 is turned OFF, no pressure increase; may be followed by error no.: 8; execution without top-up feature, insufficient initial filling or as consequence of error no.: 22-27 / check top-up functioning, leaks in equipment, system lay-out; if necessary re-fill manually, beware of error no: 11! Error OFF: self-resetting when error resolved.		6 %	19
	Maximum fill level vessel ON: Default setting has been reached or exceeded; Valves 1; 2 (3 is OFF) are switched OFF, pump motor 1; 2 are not switched ON; no pressure increase or decrease; following error may be error no.:(8) 9; improper system lay-out of initial filling / check functioning of valves 1; 2; 3; check check valves, expansion volume, drain system water (beware of error no.: 19); Error OFF, when error is resolved and reset.		A, B vessel: 96% C vessel: 81%	11
8-4- 3	Diaphragm rupture (optional) Diaphragm rupture sensor ON: Water at the electrodes of the conductive sensor; pump motors 1; 2 and 1; 2; 3 valves are turned off, no pressure increase, reduction and top-up; may be followed by error no.: 8; 9; probably diaphragm rupture/open condensate drain. If the opening results in water discharging continuously, the diaphragm should be visually checked for ruptures and leaks (note: inspect the vessel internally, which is part of the routine vessel inspection), clean the inside of the vessel, if necessary service; Error OFF, when error is resolved and reset.	OFF		20
8-4- 4	Level top-up pump (optional) Minimum fill level top-up pump ON: Insufficient level in break tank of top-up unit; top-up pump is turned off, no top-up function, feed pressure is too low, feed-valve with insufficient flow rate, may be followed by error-no.: 8; 10; 19 / check feed conditions; Error OFF, self-resetting when error is resolved.	OFF		18



Group error message menu line no.	Error, designation cause; effect/action	Default setting	Value	Error message number
8-4- 5	Minimum pressure limiter (optional) Minimum pressure limiter ON: The default setting at pressure limiter has been reached (normally closed contact has opened); pump motors 1; 2 and valves 1; 2; 3 are switched OFF (further pressure decrease will lead to vapour build-up in the heating installation) / check function of valves 1; 2, check valves, check equipment and installation for leaks (error no.: 8 is ON); Error OFF, after resolved (limiter reset) and resetting error.	OFF		17
8-4- 6	Temperature monitor (optional) Temperature monitor ON: The fixed value switch has reached or exceeded the temperature limit; scheduled de-aeration will be turned OFF and will be re-activated at lower temperature level (note: the permissible constant temperature at the vessel diaphragm is 70 °C); Error OFF: self-resetting when error resolved.	OFF	70 °C	21
8-4- 7	Motor run time Motor runtime exceeded motor 1: Default value has been reached or exceeded; suspected leakage in equipment or system, insufficient pump capacity, lockshield valve in vessel or return connection in incorrect position, improper system layout; may be followed by error no.: 8 / check system layout, electronic installation, pumps, leaks in equipment and installation, lockshield valves; insufficient pump capacity diagnosed, » Service Error OFF, when error is resolved and reset. Motor runtime of motor 2 exceeded: (see error no.: 15)	OFF	30 minutes	15
8-4- 8	Motor protection SPCx-lw: no current value after signal Motor ON SPCx-hw: Motor-circuit switch is ON	Off	...<0.0 A Setting	16
	Motor 1 SPCx-lw: current value is not reached, the temperature safety switch of the motor has been triggered due to elevated working temperatures, limiter has opened, (winding fault, power or temperature overload, no motor ventilation, exception: the power supply installation of the motor is not available or disconnected after signal "motor ON"), may be followed by error no.: 8 / ensure that medium and ambient temperature (module) are within admissible ranges, if necessary supply sufficient ventilation; check electronic installation, for recurring error » Service; Error OFF after, when error is resolved and reset. SPCx-hw: The default value of the motor protection switch has been exceeded, overcurrent (winding defect, overload, overtemperature) or an incorrect setting exists, no motor ventilation, may be followed by error no: 8 / ensure the permitted media and ambient temperatures (unit), if necessary, ensure sufficient ventilation, check the set value, and correct if necessary (type plate pump unit: For DP units, the value of the nominal current value is equivalent to the nominal current × ½ for each motor circuit switch), in case of repeated malfunction » service; Error OFF off after, when error is resolved and reset.			12
	Motor 2 (see error no.: 12) SPCx-lw / -hw: no current value after signal Motor ON		... <0.0 A	13
	Motor 3; 3.1 (top-up, drainage, option) (see error no.: 12 to SPCx-lw)			14

Group error message menu line no.	Error, designation cause; effect/action	Default setting	Value	Error message number
8-4- 9	Top-up (optional) Top-up water volume too low (pulse water meter, option). No impulse from impulse water meter after top-up request; valve 3, motor 3 are switched OFF, feed pressure too low, valve in incorrect position or not functioning properly, motor 3 with insufficient or no pump capacity; exception: Signal line is not installed or is missing, water meters without function / check electrical installation, check component functions, ensure feed conditions; Error OFF off after, when error is resolved and reset.	OFF		22
	Top-up without request (impulse water meter, option) Impulse received from impulse water meter without request for top-up, valve 3, motor 3 are switched OFF; equipment in flow direction after the water meter or valve 3 is leaking or fails to close (incorrect flow direction due to check valve blocking) / check functioning and check for leaks in the equipment; Error OFF off after, when error is resolved and reset.			23
	Minimum cycle distance exceeded			24
	Maximum no. of cycles per timeframe exceeded			25
	Maximum top-up cycle amount exceeded (impulse water meter, optional)			26
	Maximum top-up cycle time exceeded			27
8-4- 10	Overflow spill (optional) Draining amount too low (impulse water meter, optional). No impulse from impulse water meter after draining request; valve 3.1, motor 3.1 are switched OFF, feed pressure too low, valve in incorrect position or not functioning properly, motor 3.1 with insufficient or defective pump capacity; Exception: Signal line is not installed or is missing, water meter without function/check electrical installation, check component function, ensure feed conditions; Error OFF off after, when error is resolved and reset.	OFF		28
	Drainage without request (impulse water meter, option) Impulse received from impulse water meter without request for drainage, valve 3.1, motor 3.1 are switched OFF; equipment in in flow direction downstream of the water meter or valve 3.1 is leaking or fails to close (incorrect flow direction due to check valve blocking) / check functioning and check for leaks in the equipment; Error OFF off after, when error is resolved and reset.			29
8-4- 11	Treatment (optional) First message (warning), 70% of the treatment volume entered in the menu has been reached. Prepare replacement module! Reset error message.	OFF	70%	55
	Second message (warning), 90% of the treatment volume entered in the menu has been reached. This message replaces the first message , if no. 55 has not been reset. The value on the display is inverted and flashes. Prepare replacement module! (if necessary, replace module, observe error message no.: 31)		90%	61
	Third message (warning), 100% of the treatment volume entered in the menu has been reached. This message replaces the first message , if no. 61 has not been reset. The value on the display is inverted; top-up is interrupted. May be followed by error no. 19. To maintain the pressure (pressure increase), replace the module, reset the value, and then, if necessary, modify the entry for possible treatment volume, see page 32.		100%	31



Group error message menu line no.	Error, designation cause; effect/action	Default setting	Value	Error message number
8-4- 12	Maintain. 1 Carry out maintenance 1 (equipment service)	OFF	365d	56
8-4- 13	Maintain. 2 Carry out maintenance 2 (inspect vessel internally)	OFF	1825d	57
8-4- 14	Maintain. 3 Carry out maintenance 3 (inspect vessel strength)	OFF	3650d	58
8-4- 15	(Maintain. 4) Carry out maintenance 4 (routine electronic installation inspection)	OFF	584d	59
8-4- 16	Date/ time invalid Backup power for date, time is too small, not available or incorrect line entry of these data / redo or complete entry or when after complete entry error recurs » service Error OFF; error is self-resetting after resolving.	OFF		53
8-4- 17	SPCx-hw: Phase monitor (option) Phase is missing or phase sequence is incorrect, motors and valves are turned off, no pressure increase or reduction; note: the equipment supplied is installed for operation with clockwise rotating field (U/L1; V/L2; W/L3) / locate phases, check power supply fuse for this equipment, switch wiring for correct sequence; Error OFF, error is self-resetting after resolving.	OFF		30

7.9 Restarting

After long periods of downtime:

- If this downtime was planned or scheduled, turn OFF the control unit and close off the lockshield valves to the system and the isolating valve to the top-up line. After that decompress and then drain the water area. We recommend you carry out maintenance before restarting (see Maintenance section).
- Use the commissioning records for restarting and check especially for system changes that can lead to other operating conditions of the expansion automat (e.g. system pressure).

If the power supply has failed:

- The target parameters and default settings for pressure, aeration and top-up will remain unchanged, meaning automatic operation will resume automatically when power is restored (control unit ON). Extraordinary system operating conditions (e.g. cooling to below the default setting) may fall outside the permitted settings of the expansion vessel.



Caution: please ensure that when the system cools down or warms up, the minimum or maximum system pressure does not exceed or fall below the permitted operating pressure. Under- and over-pressure safety for operation of heating or cooling systems are not within the standard scope of supply of the Flamcomat.

Check the automat's operation once power supply has been restored and, if necessary, set the actual date and time values (overview menu options).

8. Maintenance

Electrical supply must be disconnected prior to conducting any maintenance. Electrical supply must be disconnected prior to conducting any maintenance. To supplement, or in addition to, the stipulations made in the overall project, perform the following:

Service interval	Object, standard scope of supply	Service activities, measures
Annually	Particle filter 3.8)*	Clean filter insert and housing
	Particle filter back-flow security (only when installed)	
	Air-intake preventer, bleeder valve 1.2)*, automatic breather 3.18)*	Clean and check function. Unscrew the cap and take out the inner spring and ball-bearing for cleaning. Re-assemble in reverse order. Screw the cap back on and open it with a single turn.
	Primer valve 3.10; 3.11)*	Check and reset the pre-sets as in diagrams (see appendix 2; seal the valve)
	Pump 3.3÷3.6)*, valve 1, 2, 3.12, 3.13)*, valve 3)*, water meter 3.14)*	Function check. To be carried out manually by trained and certified personnel. Other inspections can be done during operation of the Flamcomat equipment (observe). Bleed pumps (except for M/D 60)
	Control unit 3.19; 3.20)*, configuration	Inspect and restore the required settings (overview menu)
	Vessel 1)*, pump module 3)*	Inspect and repair the leak-tightness of all hydraulic connections to the water areas. Check the screw connections for tightness, check the exterior for damage, deformation or corrosion and restore to operational readiness.
	Safety valve 3.16)*	Function check. To be carried out manually by trained and certified personnel. This requires the lockshield valve 2.1)* on the connection assembly.

)* positions, page 18 - 21.

8.1 Vessel draining/refilling.

If draining of expansion water in the main vessel or auxiliary vessels is necessary, please consider the following order of actions:

- Record the actual volume level (%) as shown on SPC control unit display.
- Switch the control unit OFF.
- Close the lockshield valves on the expansion pipe (system inlet and outlet) and on the connecting array (vessel inlet, outlet)
- Close the isolating valve at the top-up connection.
- Carry out the required work on the vessel (drain, service, repair etc.).
- Switch the control unit ON reset to start menu (overview of menu options; menu line 11-5-7)** and run start menu procedure (overview menu options; menu-line 9...9-9)***.
- Fill the main vessel and (if applicable) the auxiliary vessels. The self-adjusting volume level can be monitored in the display of the control unit and the filling process should be interrupted at reaching the previously recorded target value.

Note: when a refill bigger than the default setting for minimum vessel filling volume is required (6%), please switch off the de-aeration function (overview menu options; menu-line 8-5-1). The filling should preferably take place over the vessel connection valve (marking). If both the main and auxiliary vessels need filling, open the lockshield valve on each vessel connection (flow and return). Make sure that the volume level detection is made by using the volume sensor of the main vessel.

- Disconnect the filling equipment.
- Open all previously closed valves (seal) and bleed the pump(s).
- Optionally the de-aeration function can be switched ON again.
- The operational mode has been restored.

** There are 3 questions in this menu item. Only when these are confirmed, the reset takes place.

*** At the moment of restarting the system some logical errors may arise that are self-acknowledging or acknowledged.

56
Maintain. 1!
1/1
Message:
Carry out equipment service!

57
Maintain. 2!
1/1
Message:
Inspect vessel internally!
Consider recurring inspections, see general safety instructions.

58
Maintain. 3!
1/1
Message:
Carry out strength inspection vessel!

59
Maintain. 4!
1/3
Message:
Carry out recurring inspection of electrical equipment!

After completion of service or planned inspection the applicable service has to be confirmed!
Example:

Maintaining
11-5

20.12.11 08:45
11-5-2
 Service 1 is due at: 20.12.2011; it results in a message at this day. After completion of service, it should be confirmed with the [enter] key (entry of date and time in upper blank line).

Fig. FM.039.V01.15



9. Decommissioning, dismantling

At the end of the of the service life or at planned shut-down of the equipment, please make sure that the module is separated from the power supply. The hydraulic system connections and top-up connections should be closed off.



Caution: water areas should first be made pressureless and empty when the destination or re-use of system water should be designated in conformity with the applicable rules. This water may be treated, contain anti-freeze or other additives.

The designation of further processing of the construction parts should be carried out in agreement with the required waste management service provider.

Appendix 1. Technical data, information

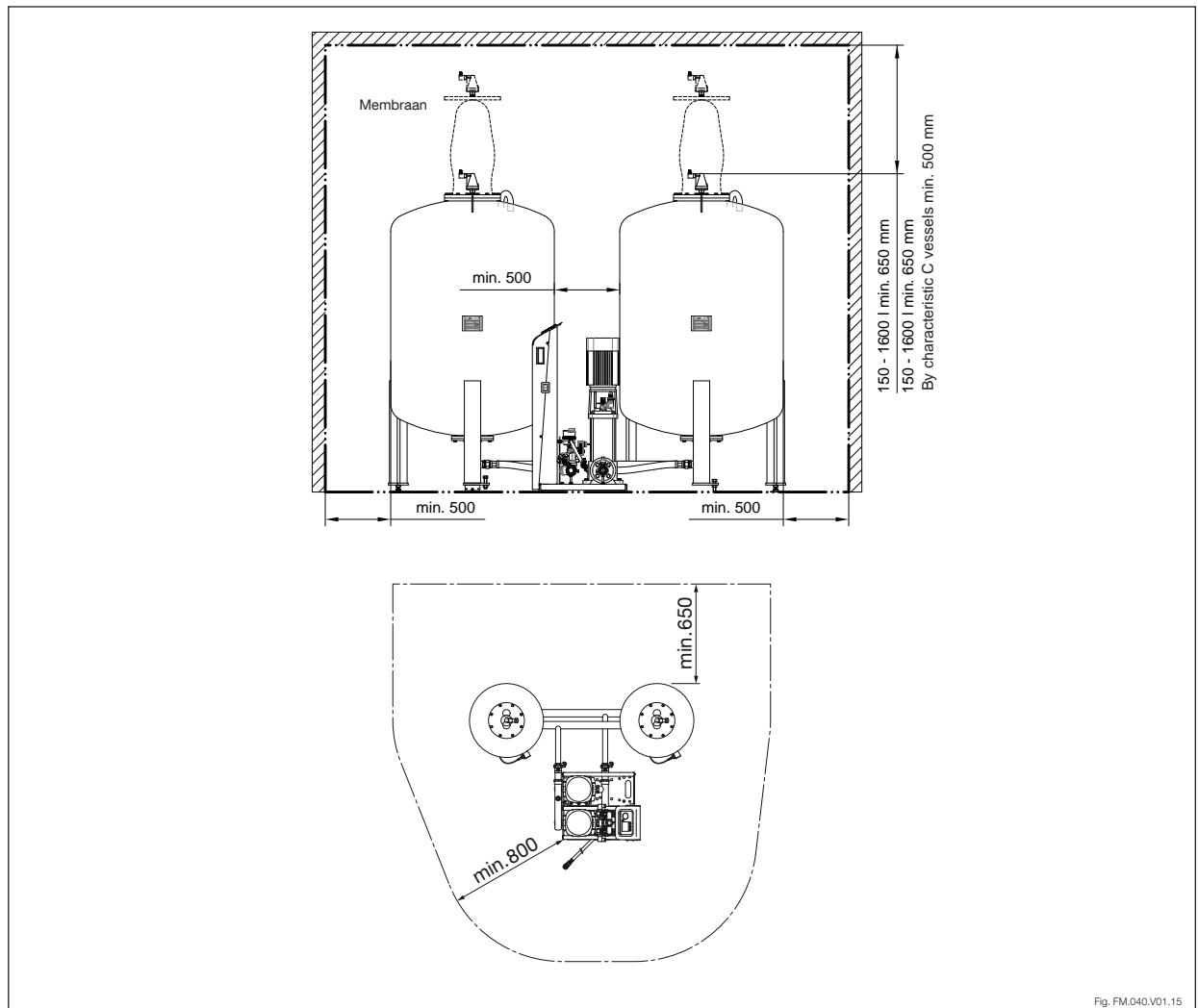
DO NOT STACK!

Ambient conditions

Storage		
Room:	Protected against:	Ambient conditions:
Locked; frost-free; dry.	Solar radiation; thermal radiation; vibration.	60 ... 70 % relative humidity, non-condensing; maximum temperature 50 °C; free of electrically conductive gases, explosive gas mixtures, aggressive atmosphere.

Operations room		
Room:	Protected against:	Ambient conditions:
Locked; frost-free, dry.	Solar radiation; thermal radiation; vibration.	60 ... 70 % relative humidity, non-condensing; temperature 3 - 40 °C; depending on type 3 - 50 °C; free of electrically conductive gases, explosive gas mixtures, aggressive atmosphere. Caution: Higher temperatures may lead to overload of the drive system.

Minimum distances





Installation examples

Distance system supply, system discharge, at return integration point, in the range 0.5 ... 1 ... m.

Please note: If the return line is routed horizontally, do not implement the connection from below to avoid additional contamination with dirt.

¹⁾ For design temperatures > 100 °C and > 110 °C, additional requirements from applicable European standards may apply.

²⁾ Not required acc. to DIN EN 12828

³⁾ Add additional auxiliary vessels symmetrically using a collector line (main vessel at centre) taking into account minimum distances. The branch from the main vessel must be flexible.

■** accessory, optional extra

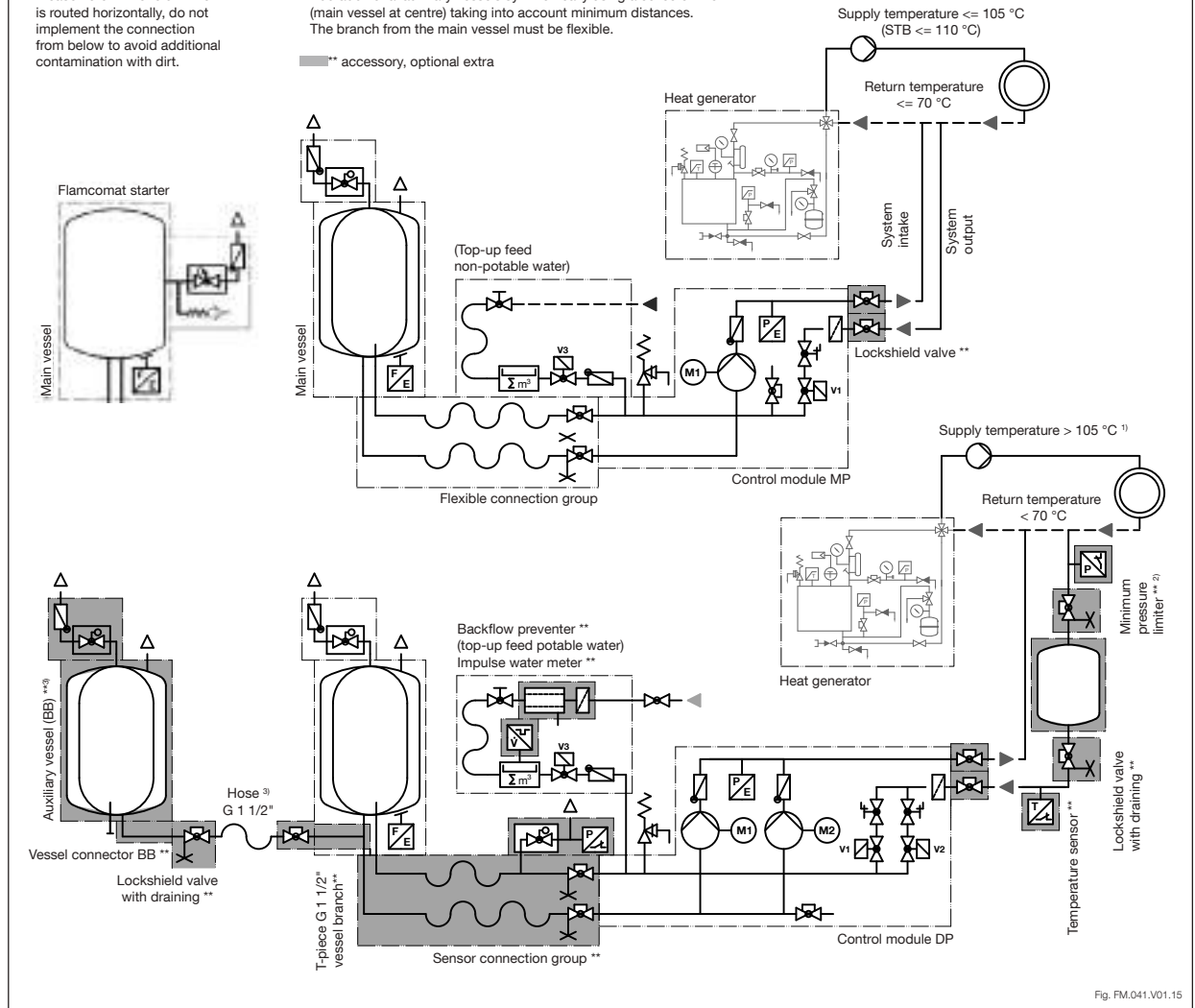


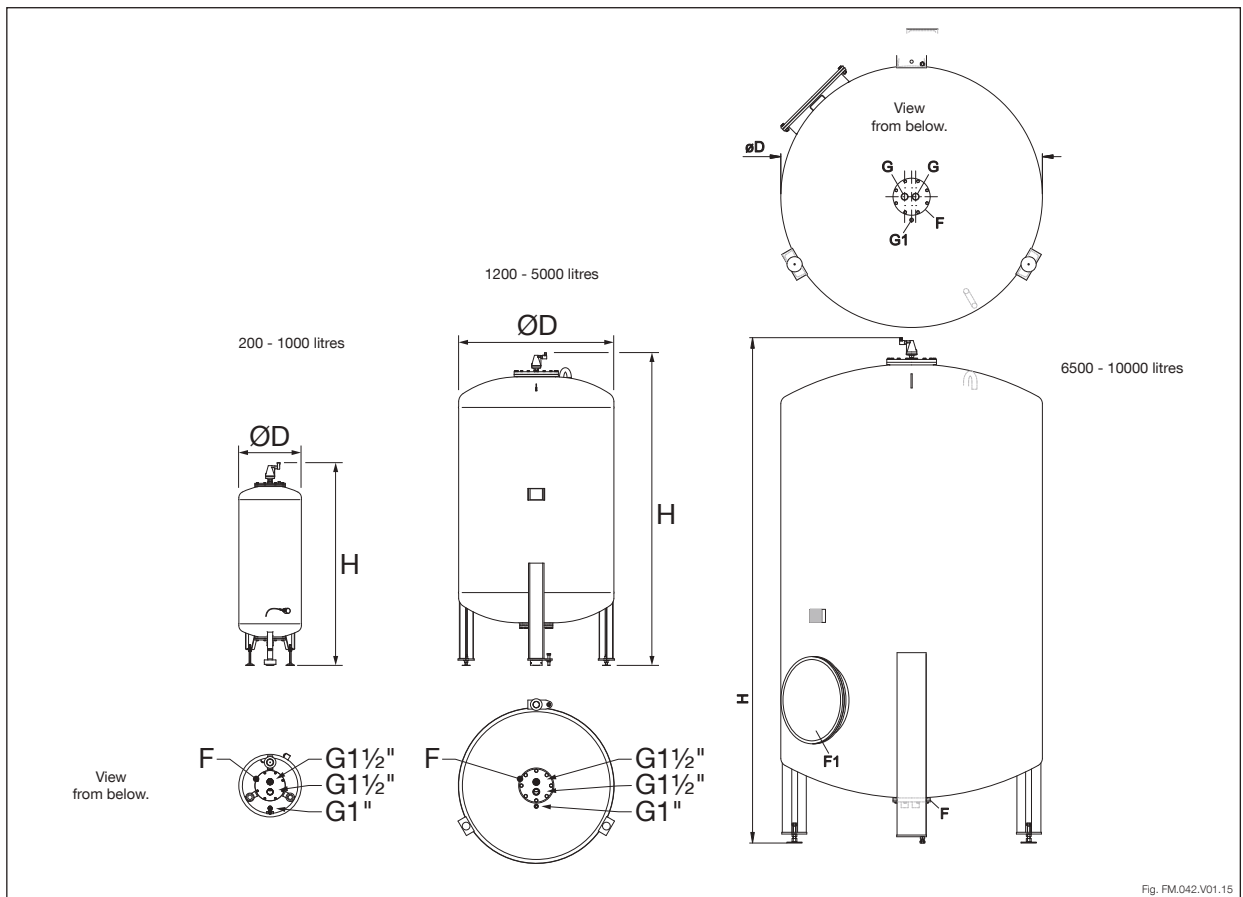
Fig. FM.041.V01.15

Appendix 2. Technical data, specifications, hydraulic equipment

ENG

Vessels: volume, dimensions and weights

Nominal capacity	Vessel diameter D (Characteristic C)	Maximum height H (Characteristic C)	Vessel connector feed return G	Condensate drain G1	Vessel flange F	Vessel flange F1	Deadweight (as delivered, without packaging) (Characteristic C)
[litres]	[mm]	[mm]	[G; inch]	[G; inch]	[DN]	[DN]	[kg]
100	484 (484)	1050 (904)	1½"	½"	165		35 (27)
200	484 (600)	1560 (1081)	1½"	½"	165		31 (42)
300	600 (600)	1596 (1451)	1½"	½"	165		41 (56)
400	790 (790)	1437 (1293)	1½"	½"	165		62 (76)
500	790	1587	1½"	½"	165		70
600	790 (790)	1737 (1653)	1½"	½"	165		77 (97)
800	790	2144	1½"	½"	165		92
1000	790	2493	1½"	½"	165		106
1200	1000	2210	1½"	½"	165		291
1600	1000	2710	1½"	½"	165		346
2000	1200	2440	1½"	½"	165		431
2800	1200	3040	1½"	½"	165		516
3500	1200	3840	1½"	½"	165		626
5000	1500	3570	1½"	½"	165		1241
6500	1800	3500	1½"	½"	165	500	1711
8000	1900	3650	1½"	½"	165	500	1831
10000	2000	4050	1½"	½"	165	500	2026





Vessel: operational characteristics

Nominal capacity	Permissible positive operating pressure	Positive test pressure	Temperature min. (design)	Temperature max. (design)	Permissible permanent temperature at the diaphragm min.	Permissible permanent temperature at the diaphragm max.
[litres]	[bar]	[bar]	[°C]	[°C]	[°C]	[°C]
100 - 10000	3	4,72	0	120	0	70

Pump module: dimensions and weights

Type		Height	Length	Width	Connection	Connection system	Connection top-up	Dead weight (as delivered condition without packaging)
		[mm]	[mm]	[mm]	[G, inch]	[G, inch]	[Rp, inch]	[kg]
MP M-2-50	(MM G3)	922	506	227	1" M	1 ¼" F	½"	22
MP 2-3-50	(M02 G3)	922	540	227	1" M	1 ¼" F	½"	28
MP 10-1-50	(M10 G3)	922	513	227	1" M	1 ¼" F	½"	35
MP 20-2-50	(M20 G3)	922	553	227	1" M	1 ¼" F	½"	35
MP 60-1-50	(M60 G3)	922	561	227	1" M	1 ¼" F	½"	53
MP 80-1-50	(M80 G3)	937	593	299	1" M	1 ¼" F	½"	68
MP 100-1-50	(M100)	1030	610	595	1 ½" F	1 ½" F	½"	67
MP 130-1-50	(M130)	1190	610	595	1 ½" F	1 ½" F	½"	75
DP M-2-50	(DM G3)	942	506	267	1" M	1 ¼" F	½"	29
DP 2-3-50	(D02 G3)	974	603	452	1" M	1 ¼" F	½"	45
DP 10-1-50	(D10 G3)	974	583	452	1" M	1 ¼" F	½"	61
DP 20-2-50	(D20 G3)	974	620	446	1" M	1 ¼" F	½"	61
DP 60-1-50	(D60 G3)	974	594	444	1" M	1 ¼" F	½"	61
DP 80-1-50	(D80 G3)	975	594	515	1" M	1 ¼" F	½"	115
DP 100-1-50	(D100)	1030	910	580	1 ½" F	1 ½" F	½"	134
DP 130-1-50	(D130)	1190	910	580	1 ½" F	1 ½" F	½"	153

Control module external pressure retention, operational characteristics

Type		Permissible positive operating pressure	Permissible media temperature min. / max.	Permissible environmental temperature min. / max.
		[bar]	[°C]	[°C]
MP M-2-50	(MM G3)	6	3 / 70	3 / 40
MP 2-3-50	(M02 G3)	10	3 / 70	3 / 40
MP 10-1-50	(M10 G3)	10	3 / 70	3 / 50
MP 20-2-50	(M20 G3)	10	3 / 70	3 / 40
MP 60-1-50	(M60 G3)	10	3 / 70	3 / 50
MP 80-1-50	(M80 G3)	16	3 / 70	3 / 50
MP 100-1-50	(M100)	16	3 / 70	3 / 50
MP 130-1-50	(M130)	16	3 / 70	3 / 50
DP M-2-50	(DM G3)	6	3 / 70	3 / 40
DP 2-3-50	(D02 G3)	10	3 / 70	3 / 40
DP 10-1-50	(D10 G3)	10	3 / 70	3 / 50
DP 20-2-50	(D20 G3)	10	3 / 70	3 / 40
DP 60-1-50	(D60 G3)	10	3 / 70	3 / 50
DP 80-1-50	(D80 G3)	16	3 / 70	3 / 50
DP 100-1-50	(D100)	16	3 / 70	3 / 50
DP 130-1-50	(D130)	16	3 / 70	3 / 50



Control module external pressure retention, manual control valve, adjustment values

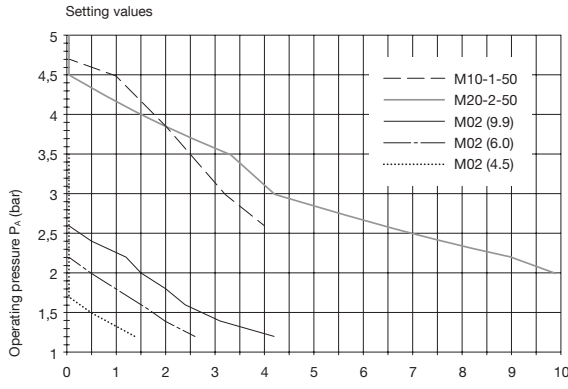


Fig. FM.045.V01.15

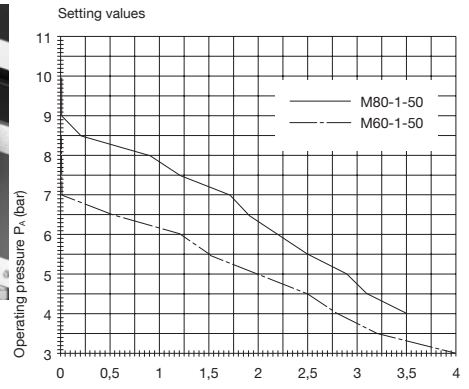


Fig. FM.046.V01.15

Setting values manual regulated valve M02 after pump see paragraph "Component parts", equipment [3,23].

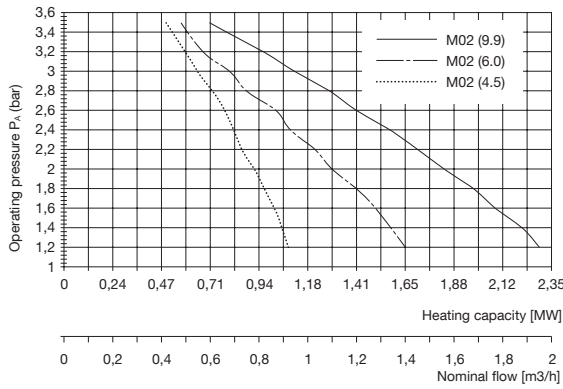


Fig. FM.047.V01.15

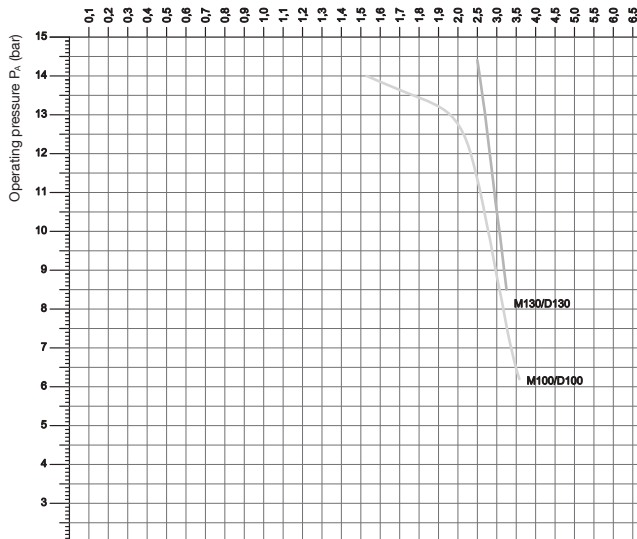


Manual control valve
 (Pos. 3.10; 3.11; page 19...21)
 Version MP (M ÷ M130) - Valve 1,
 Version DP (D ÷ D130) - Valve 1 and 2

Example MP / DP 02-2-50 (M02/D02):
 Operating pressure 3.8 bar

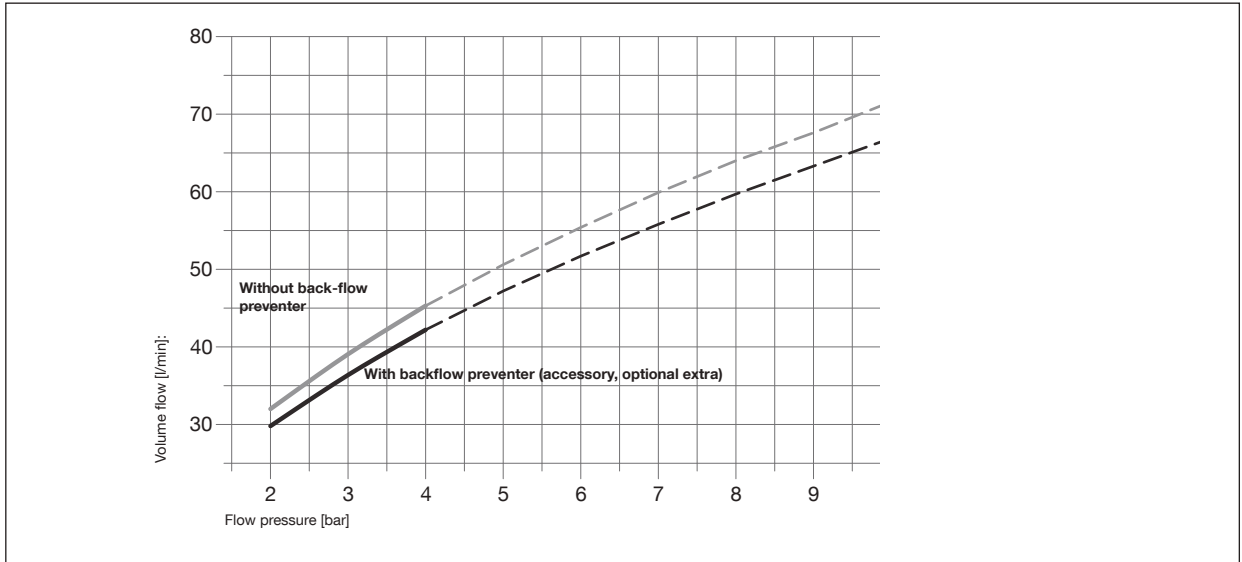


Fig. FM.048.V01.15





Control module external pressure retention, top-up, flow rate



Appendix 3. Technical data, information, electrical equipment

Pump unit, nominal values

Type	Nominal voltage	Rated current [A]	Rated power [kW]	External fuses T (K) [A]	Protection class of pump unit *)
MP M-2-50 (MM G3)	230 V ~1 N PE 50 Hz	0.43	0.09	16	IP44
MP 2-3-50 (M02 G3)	230 V ~1 N PE 50 Hz	2.77	0.62	16	IP54
MP 10-1-50 (M10 G3)	230 V ~1 N PE 50 Hz	4.4	0.75	16	IP54
MP 20-2-50 (M20 G3)	230 V ~1 N PE 50 Hz	7.2	1.1	16	IP54
MP 60-1-50 (M60 G3)	230 V ~1 N PE 50 Hz	7.4	1.1	16	IP54
MP 80-1-50 (M80 G3)	400 V ~3 N PE 50 Hz	3.4	1.5	16	IP54
MP 100-1-50 (M100)	400 V ~3 N PE 50 Hz	4.75	2.2	16	IP54
MP 130-1-50 (M130)	400 V ~3 N PE 50 Hz	6.4	3.0	16	IP54
DP M-2-50 (DM G3)	230 V ~1 N PE 50 Hz	0.86	0.18	16	IP44
DP 2-3-50 (D02 G3)	230 V ~1 N PE 50 Hz	5.54	1.24	16	IP54
DP 10-1-50 (D10 G3)	230 V ~1 N PE 50 Hz	8.8	1.5	16	IP54
DP 20-2-50 (D20 G3)	230 V ~1 N PE 50 Hz	14.4	2.2	16	IP54
DP 60-1-50 (D60 G3)	230 V ~1 N PE 50 Hz	14.8	2.2	16	IP54
DP 80-1-50 (D80 G3)	400 V ~3 N PE 50 Hz	6.8	3.0	16	IP54
DP 100-1-50 (D100)	400 V ~3 N PE 50 Hz	9.5	4.4	16	IP54
DP 130-1-50 (D130)	400 V ~3 N PE 50 Hz	12.8	6.0	16	IP54

* Protection, Control unit SPCx-lw / hw: IP54.

Control unit, terminal plana

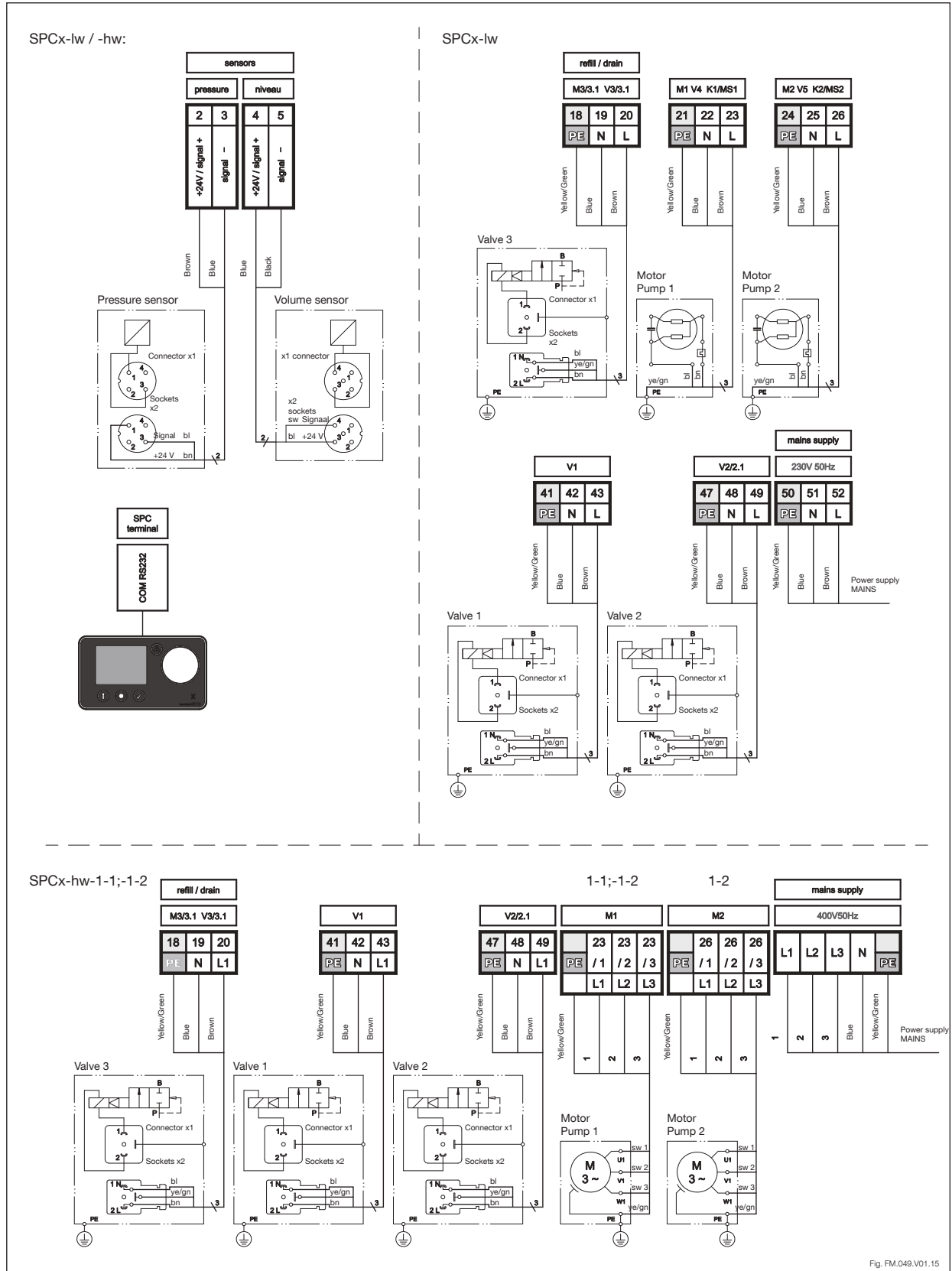


Fig. FM.049.V01.15



Appendix 4. Declaration of Conformity



Flamco

EU Declaration of Conformity EU Konformitätserklärung

Manufacturer
Hersteller

Flamco BV
Amersfoortseweg 9, 3750 GM Bunschoten, the Netherlands

Product description
Produktbezeichnung

Expansion automat
Druckhalteaggregate

Product type
Produkt Typ

Flamcomat

This declaration of conformity is issued under the sole responsibility of the manufacturer.

Die alleinige Verantwortung für die Ausstellung dieser Konformitätserklärung trägt der Hersteller.

The object of the declaration described above is in conformity with the relevant Union harmonisation legislation:

Der oben beschriebene Gegenstand der Erklärung erfüllt die einschlägigen Harmonisierungsrechtsvorschriften der Union:

Machinery Directive / Maschinenrichtlinie
2006/42/EC

Pressure Equipment Directive / Druckgeräte-Richtlinie
2014/68/EU

Low Voltage Directive / Niederspannungsrichtlinie
2014/35/EU

EMC Directive / EMV-Richtlinie
2014/30/EU

The conformity of the product described above with the provisions of the applied Directive(s) is demonstrated by compliance with the following Standards / regulations:

Die Übereinstimmung des bezeichneten Produkts mit den Vorschriften der angewandten Richtlinie(n) wird nachgewiesen durch die Einhaltung folgender Normen / Vorschriften:

EN 61000-6-1

EN 61000-6-3

EN 13831 / AD 2000

Bunschoten, 07.10.2016

Signed for and on behalf of: / *Unterzeichnet für und im Namen von:*

FLAMCO BV

M. van de Veen
Managing director



Flamco



Flamco B.V.

Amersfoortseweg 9
3751 LJ Bunschoten
the Netherlands
T +31 33 299 75 00
F +31 33 298 64 45
E info@flamco.nl
I www.flamcogroup.nl

Copyright Flamco B.V., Bunschoten, the Netherlands.
No part of this publication may be reproduced or published in
any way without explicit permission and mention of the source.
The data listed are solely applicable to Flamco products.
Flamco B.V. shall accept no liability whatsoever for incorrect
use, application or interpretation of the technical information.
Flamco B.V. reserves the right to make technical alterations.

