



Flamco

ENG

ENA 7-30

Installation and operating instructions



© Flamco

www.flamcogroup.com

TP.03/24/09.EN

Edition 2009 / EXP

3



Contents		Page
1. General		5
1.1.	About this manual	5
1.2.	Other supplied documentation	5
1.3.	Use of Flamco products	5
1.4.	Further help and information	5
2. Safety		5
2.1.	Intended use	5
2.2.	Important information	5
2.3.	Signs in this manual	5
2.4.	Specifications	5
2.5.	Safety devices	5
2.5.1.	Avoiding excessive pressure	5
2.5.2.	Avoiding excessive temperature	6
2.6.	Signs on the automat	6
3. Description		7
3.1.	Component overview	7
3.2.	Controller SCU	8
3.3.	Working principle	8
3.3.1.	Deaeration	8
3.3.2.	Make-up operation	8
4. Transport and storage		9
4.1.	Transport	9
4.2.	Storage	9
5. Installation		10
5.1.	Prepare for installation	10
5.2.	Ambient conditions	10
5.3.	Hydraulic installation	11
5.4.	Electrical installation	11
5.5.	Basic electrical connections	12
6. Startup controller		13
6.1.	Controller menu structure	13
6.2.	Menu symbols	13
6.3.	Working principle controller	14
6.4.	Controller inputs	15
7. Maintenance and troubleshooting		16
7.1.	Before maintenance	16
7.2.	After a power failure	16
7.3.	Maintenance interval	16
7.4.	Change the automat for water treatment	16
7.5.	Error messages	17
8. Disposal		18
9. Technical specifications		19



1 General

1.1 About this manual

This manual includes technical specifications, instructions and explanations that helps to use this automat safely. Read and understand all the instructions before you transport, install, commission, restart, operate or maintain the automat.

1.2 Other supplied documentation

General information of additional components, such as the pump and the sensors, is included in this manual. If additional documentation is supplied, also follow the instructions in those.

1.3 Use of Flamco products

According to order or execution complementary documentations can be added. Follow the positions performed in the dispatch papers.

1.4 Further help and information

Contact your local supplier for additional services as:

- Training.
- Maintenance agreements.
- Service contracts.
- Repairs and improvements.

2 Safety

2.1 Intended use

The automat is designed for deaerating and feeding make-up water in closed heating and in cooling water systems. The automat is not designed for the initial filling or re-filling of systems.

2.2 Important information

The automat has safety devices intended to prevent injury and damage. Use the automat in the following way:

- Have the installation be carried out by qualified personnel.
- Comply with local legislation and guidelines.
- Do not make modifications to the automat without prior written permission of Flamco.
- Make sure that all automat covers and doors are closed when operating the automat.
- Do not touch live voltage. The sensor units and the capacity pressure sensors operate with extra low safety voltage.

Flamco shall not be liable for any losses arising from the non-observance of safety conditions or as a consequence of the disregard of standard precautionary measures when performing such services as transport, installation, commissioning, re-starting, operation, maintenance, testing and repair, even in the event that these are not expressly described in these instructions.

2.3 Signs in this manual



Identifies a hazard that could lead to personal injury including death/damage to the automat, damage to other equipment and/or environmental pollution.



Identifies an electric hazard that could lead to personal injury including death/damage to the automat, damage to other equipment and/or environmental pollution.



Earthing



Important information.

2.4 Specifications

The construction of the automat is designed in accordance with the norms DIN EN 12828.

2.5 Safety devices

The automat does not contain any safety components that prevent that the operation pressure and the operation temperature range are exceeded or go below a limit. Install components for the limitation of pressure and temperature in the system.

2.5.1 Avoiding excessive pressure

Appropriate safety valves that prevent that the maximum operation pressure is exceeded:

- Open not later than the maximum allowable working pressure is reached.
- Can conduct the occurring volume flow (including the maximum possible refilling volume) up to the 1.1-fold of the maximum operation pressure;
- Have a proven reliability or are certified.



Do not narrow the inlet or outlet piping of the safety valve.



Installation and operating instructions

2.5.2 Avoiding excessive temperature

Appropriate safety components:

- Guarantee that the operation temperature range is not exceeded at any point of the system;
- Are approved and tested on operation safety.



Activate the pressure and temperature safety devices and check them regular on proper working.

2.6 Signs on the automat

The signs on the automat are part of the safety provisions. Do not cover or remove the signs. Inspect regularly if the signs are present and legible. Replace or repair signs that are illegible or damaged.

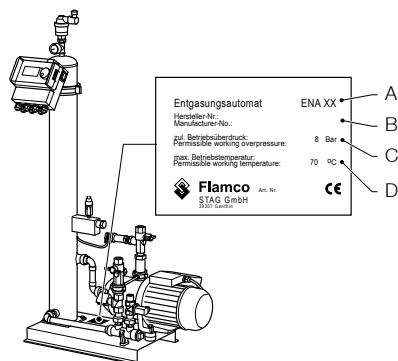

On the type plate the following product information can be found:

- A Automat type (ENA 10, 20 or 30)
- B Automat serial number
- C Permissible working overpressure
- D Permissible working temperature



Do not use the automat when the specifications on the type plate differ from the order.

Installation and operating instructions

3 Description

3.1 Component overview

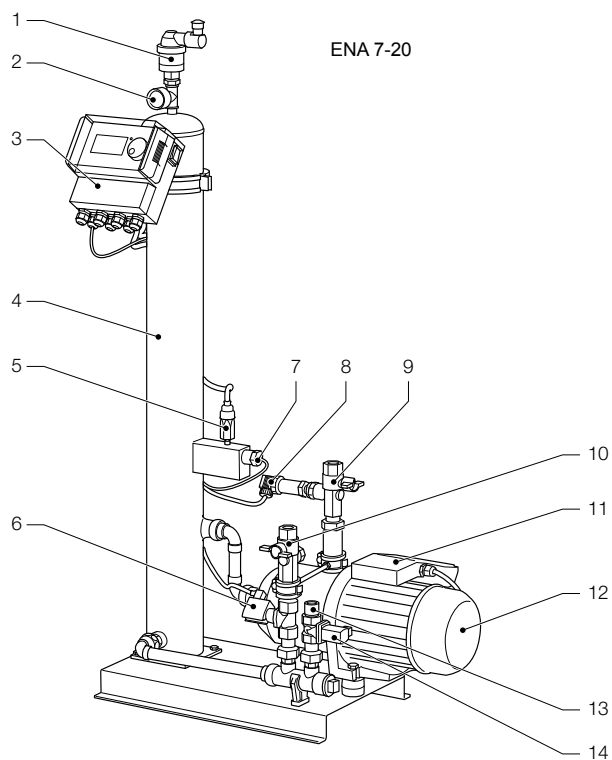

No.	Description
1	Vent. device
2	Pressure gauge
3	SCU controller
4	Vacuum tank
5	Vacuum pressure switch
6	Solenoid valve N.O.
7	Float switch
8	Pressure sensor
9	Connection to system Rp3/4"
10	Connection from system Rp3/4" *
11	Terminal box pump 1
12	Pump 1
13	Connection for refill Rp3/4"
14	Solenoid valve N.C.
15	Terminal box pump 2
16	Pump 2

* with strainer

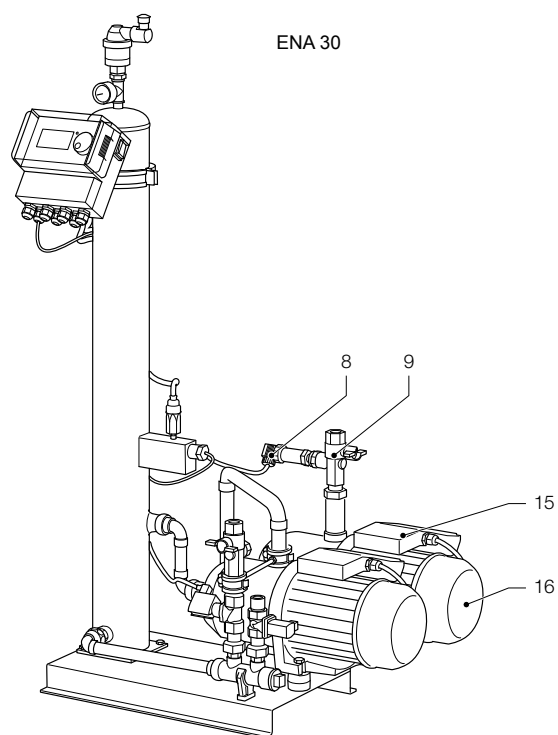



Installation and operating instructions

3.2 Controller SCU

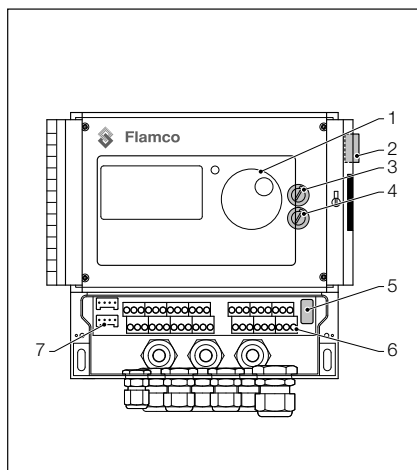

No.	Description
1	Control panel for the controller, graphical display, LED for error display, selector switch (click and roll)
2	Power switch, ON: flashes red
3	Internal fuse F1: T 16 A 250 V
4	Internal fuse F2: T 3,5 A 250 V
5	Hardware release, service menu E2
6	Terminal bars for <ul style="list-style-type: none"> • Electric supply; • sensors; • Impulse water counter; • External activation for refilling process; • Collective malfunction message; • Pump.
7	Interface RS485.

3.3 Working principle

The automat serves primarily as an active deaerating device. In addition as a make-up device for re-filling the water losses in a system.

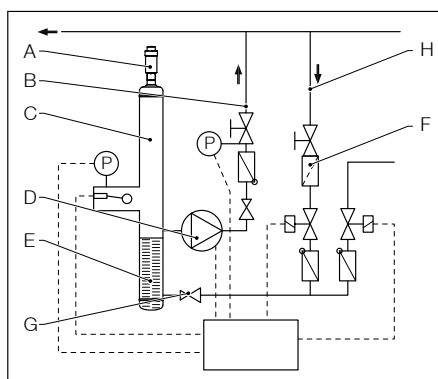

3.3.1 Deaeration

For deaerating the water, the system water is drawn in via a bypass from the return line of the system (H). The water is run through a flow regulator (G) and the strainer (F) into the deaeration tank (C). It is subjected to a vacuum during the cyclic running of the pump (D) and passed through a ring packing (E). As a result of the lowered pressure, and the large surface of the ring packing, air dissolves from the water.

When the pump switches off, the replenishing medium flowing into the tank causes the pressure in the tank to increase to the level of the system pressure so that the air which has accumulated above the water level is discharged via the vent device (A). While the pump is running, the water quantity supplied into the tank is returned via a bypass line to the return branch (B) of the system.

Fast deaeration mode (Fast = Turbo):

An interval during which the pump is running (vacuum is forming) alternates with an interval during which the air is discharged (pump is stopped).

Normal deaeration mode:

An additional pause is added between the end of the evacuation interval and the starting of the pump. This additional interval can be selected via a parameter within fixed limits. Upon expiry of the deaeration interval, the system changes to the normal deaeration mode, which then takes place continuously. The normal deaeration mode is interrupted by a selectable pause (by default 06.00 p.m. - 08.00 a.m.). The beginning of the next deaeration cycle taking place in the normal deaeration mode is indicated via a countdown in the Process menu.

3.3.2 Make-up operation

The make-up water is supplied in a pressure-controlled or level-controlled mode. The automat is set by default to pressure-controlled refilling (if a diaphragm expansion vessel is used).

Pressure-controlled supply:

The system is equipped with a pressure sensor (P) for sensing the pressure. The make-up activating pressure should be $P_{o^*} + 0.2$ bar. The make-up deactivating pressure must be at least 0.1 bar higher than the make-up activating pressure. The make-up water flow rate or feed time can be monitored, if the system is fitted with a litres counter. The pump (D) must be automatically stopped cyclically during pressure-controlled refilling, and the actual system pressure must be checked and, if necessary, additional water must be supplied until the make-up deactivating pressure is reached.

Level-controlled supply:

In this case, make-up water is supplied as long as the external make-up request is active and the flow-rate and time monitoring feature of the automat allows making up to take place.

It is possible to deactivate the make-up function. Refer to chapter 6.1.

* $P_o = P \text{ Static} + P \text{ Steam}$



4 Transport and storage

4.1 Transport

The shipping papers list all the items, such as equipment and documentation. Ensure that the delivery is complete and not damaged. The automat is packed horizontally on disposable pallets and are fully assembled.



Identify the items that are missing or not correctly delivered. Read the general terms and conditions in the shipping papers.

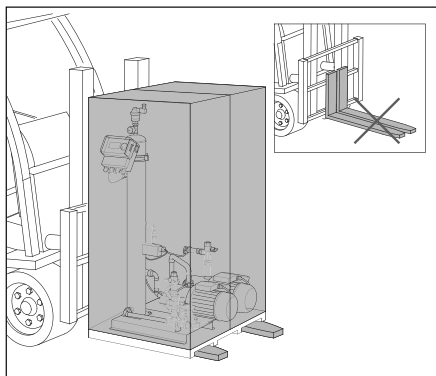

- Transport the pallets horizontally.
- Lift the automat just slightly.



Make sure that the lifting device can support the automat. For weight and dimensions, refer to chapter 9: Technical specifications.

4.2 Storage

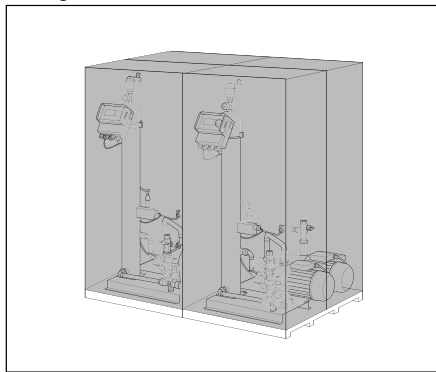

Make sure that the storage space meets the ambient conditions. Refer to section 6.2.

- Take care for an even floor.



Do not stack up.



Flamco

Installation and operating instructions

5 Installation

5.1 Prepare for installation



Make sure that the surface can support the maximum weight of the automat, including the water. Refer to chapter 9: Technical specifications.

- The automat may not be affected by external forces.
- No dirt may get into the automat and its accessories.
- Install shut-off devices to the drinking water net on-site.
- Plan enough free space around the automat for maintenance work.
- Note the effective regulations regarding the use and the installation location and, if necessary, inform the responsible testing and certification bodies prior to the launch of the system.

5.2 Ambient conditions

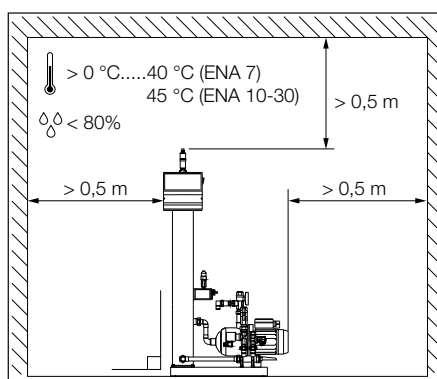

Make sure

- that the automat is level;
- that the automat is installed in a closed, dry and frost-free room;
- to maintain the minimum distances as indicated;
- that the atmosphere does not contain electrically conducting gases or high concentrations of dust and vapors. Risk of explosion when there are combustible gases;
- that the vicinity is clean and well lit.
 - Relative humidity: not condensating.
 - Free of vibrations.
 - Free from heat- and solar radiation.
- that the automat is free from additional loads.



Installation and operating instructions

5.3 Hydraulic installation



- Install the shut-off devices on-site in front of the tube joints.
- Only work on non-pressurised and cooled-down pressure joints.

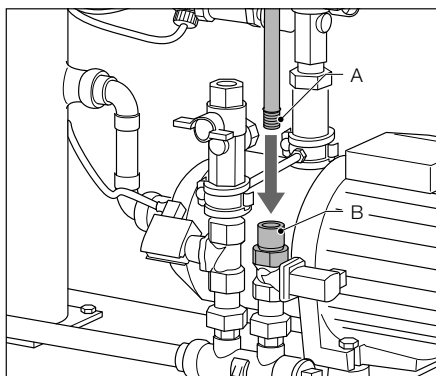

- Connect the supply line to the refilling supply.
- If necessary, install a dirt trap at the drinking water joint (0.2 mm).
- The minimum nominal diameter for the installation line of the system and the supply line is DN 20.

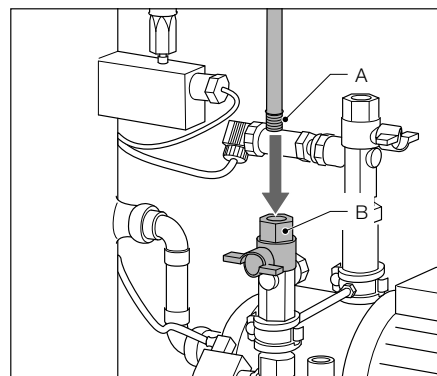

- Connect the return line of the system to the inlet of the ENA.

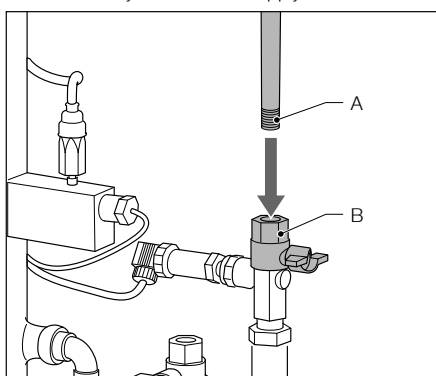

- Connect the supply line of the system to the pressure side of the ENA.

5.4 Electrical installation



There can be live voltage on the terminal bars even when the main power supply is disconnected. Make sure all external power supplies (e.g. external refill equipment) are also disconnected from the automat.

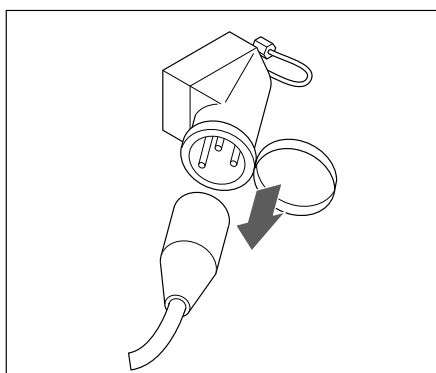

- Switch off the power switch on the controller SCU.
- Pull the power plug or switch off external separators and secure these against a restart.

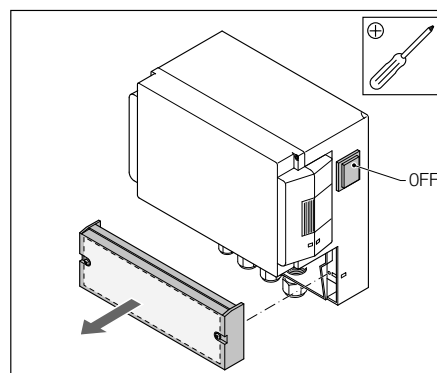

- Unscrew the protective cover of the terminal box.
- The descriptions of the terminal bars are on the inside of the protective cover.



Installation and operating instructions

5.5 Basic electrical connections

	ENA 7	ENA 10	ENA 20	ENA 30
Nominal voltage	230 V: +6%; -10%; 50 Hz: +1%; -1%			
Nominal current	2.77 A	5.3 A	7.2 A	10.6 A
Nominal power	0.62 kW	1.1 kW	1.51 kW	2.2 kW
Safety current	10 A			16 A
Protection type	IP55		IP54 (pressure sensor IP65)	

SELV: Safety Extra Low Voltage

* Recommended value; Line safety switch (C).



Never connect terminal 11+12 and 21+22 at the same time. It will destruct the refill the SCU controller or the pressure holding control.

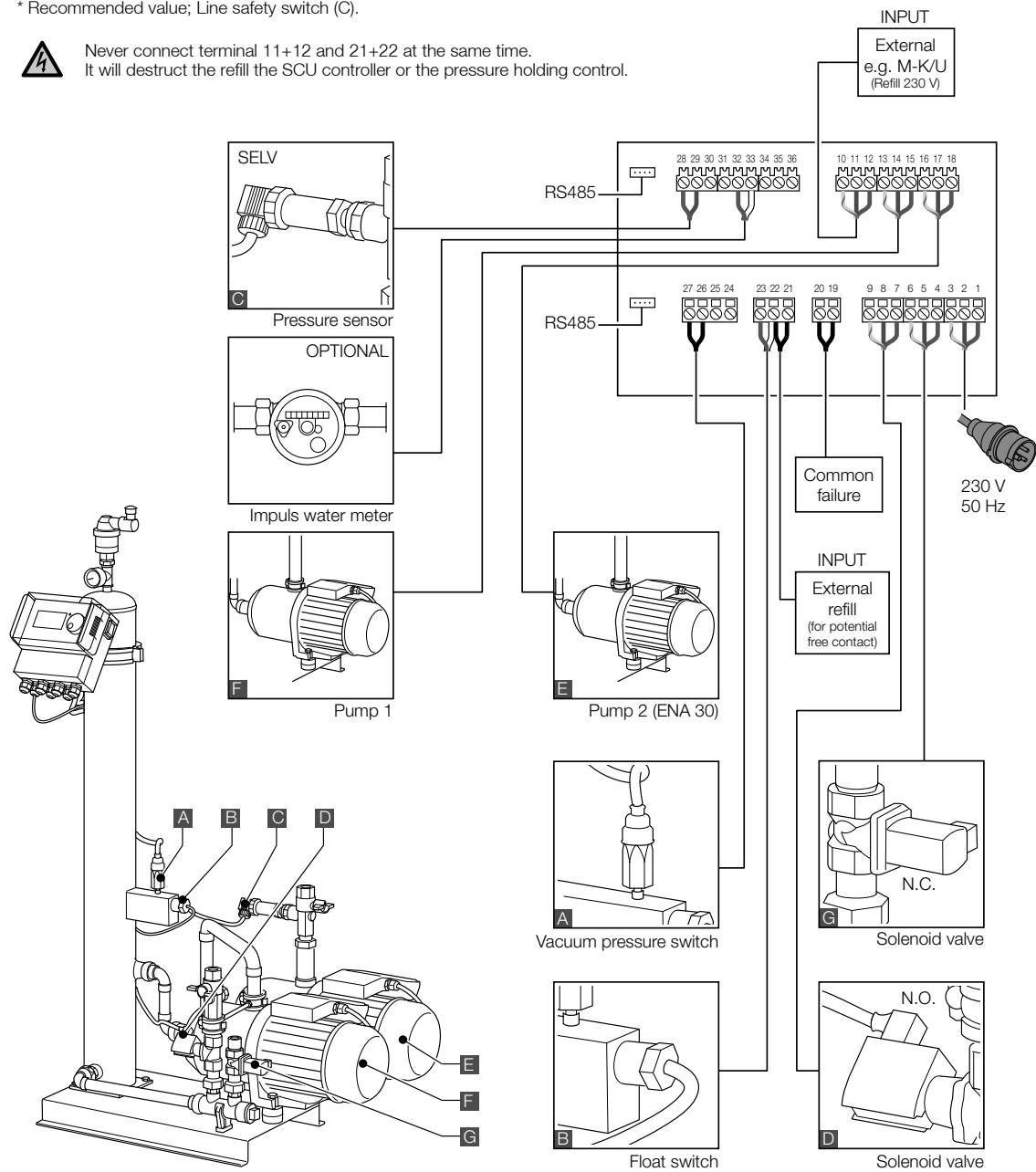



Installation and operating instructions

6 Startup controller

6.1 Controller menu structure

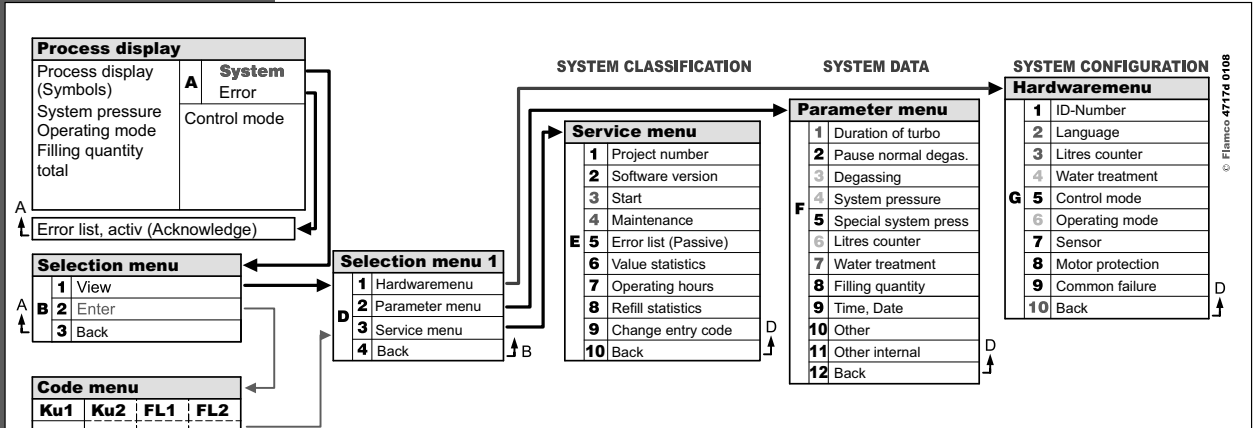

6.2 Menu symbols

	No ID number available. Controller not configured.		Pump
	Denied, not installed. Outside parameter limits.		Float switch.
	Refill is pressure controlled.		Entry confirmed.
	Code required.		Programming mode, enter.
	Refill is level controlled.		Test mode.
	Solenoid valve.		Warning.
	No intervention possible.		Save error. Settings not saved.
	Operating mode, view only.		Wait.
	Vacuum switch.		External refill signal is connected (level controlled operation only).



Installation and operating instructions

6.3 Working principle controller

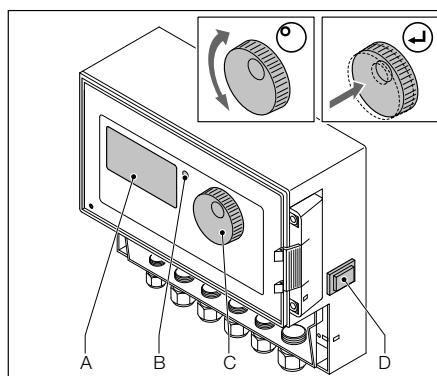

Start up

- Switch off an installed refill equipment. Close the inflow valves.
- Switch on the controller (D).

- A Display
- B Error LED
- C Navigation wheel
- D ON/OFF switch controller

Use the navigation wheel (C) to navigate through the menus and to confirm the input. The display (A) shows the menus. In case of errors the error LED (B) is on.

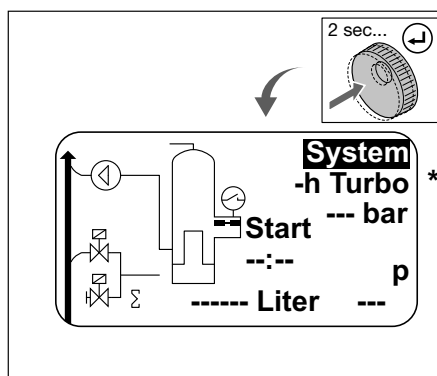

- Hold down the navigation wheel for two seconds to go to the process display, whatever the cursor position.

* Turbo = Fast

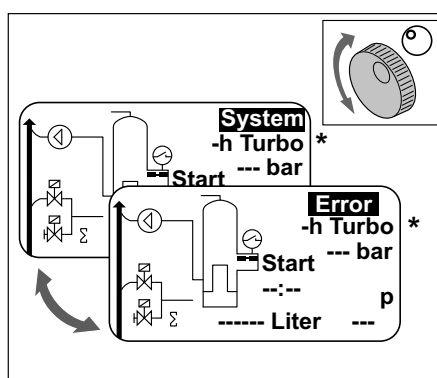

- In case of errors the process display switches from [SYSTEM] to [ERROR] and the LED is on.
- The error messages, minimum water level, minimum pressure alarm are consistent by the first start of operation.
- It is possible to turn the wheel to switch between [SYSTEM] and [ERROR].
- When [ERROR] is displayed press the wheel to go to the error list. In case of more than one error, scroll through the errors. All errors are shown in accordance of appearance.
- When [SYSTEM] is displayed, press the wheel to go to the option menu.

* Turbo = Fast

Installation and operating instructions

6.4 Controller inputs

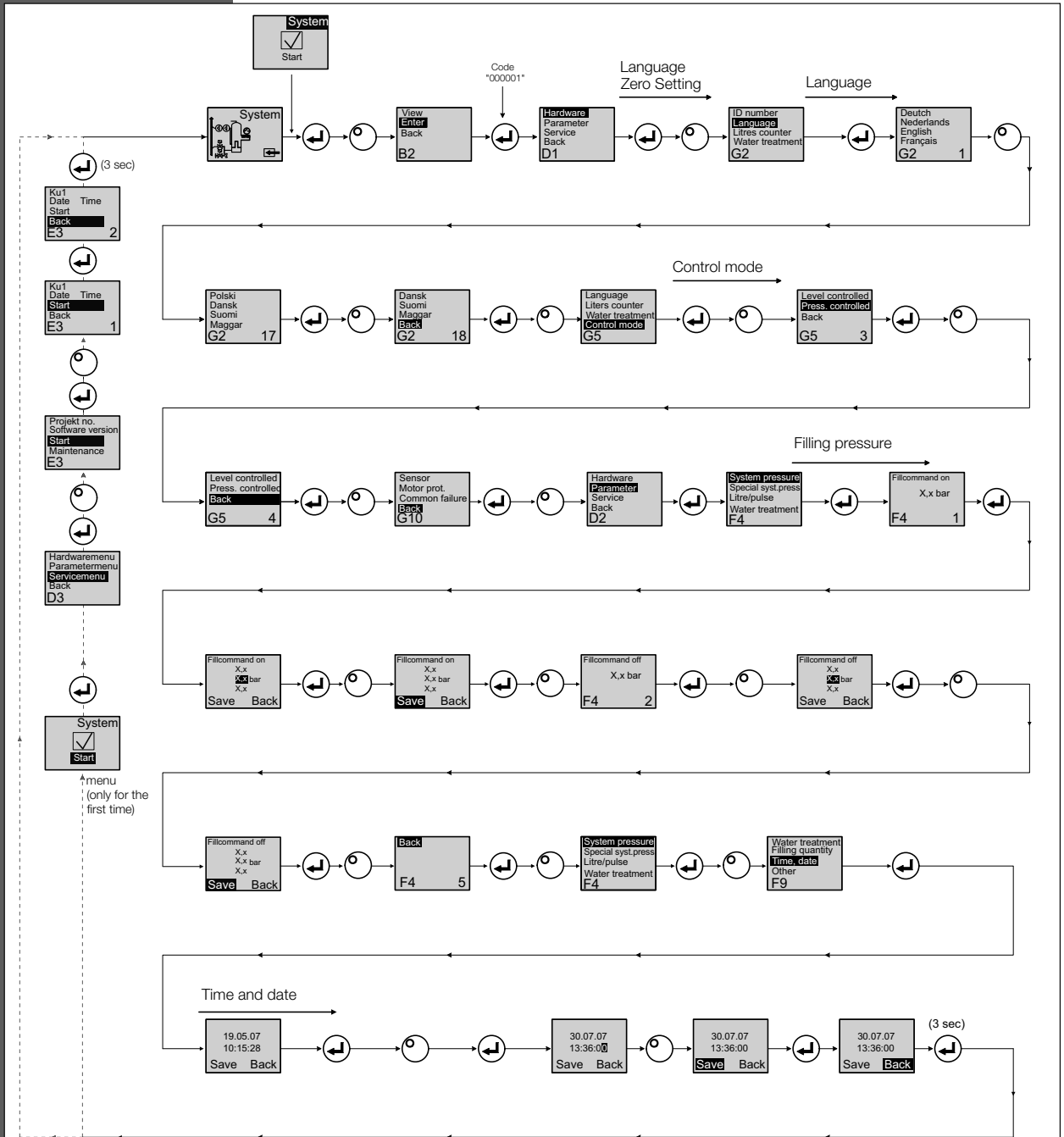

- When entering the program mode, the control for pressure maintenance is active.
- The code will be active 5 minutes after latest input.
- Remove all unpermitted loads, supported objects or lateral loads from the basic automat.
- When the programming procedure is completed, the electrical parts of the ENA are ready for operation.



Installation and operating instructions

7 Maintenance and troubleshooting



- The water and the contact surfaces can be 70 °C or more.
- Wear the required protective clothing.
- The floor can be wet or greasy. Wear protective shoes.

7.1 Before maintenance

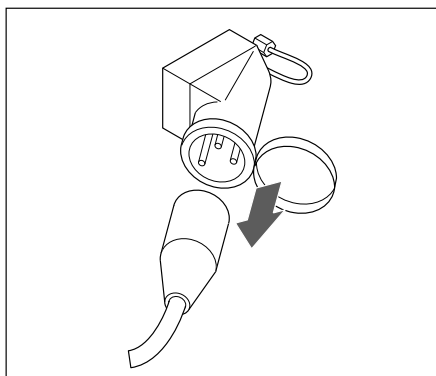

There can be life voltage on the terminal bars even when the main power supply is disconnected. Make sure all external power supplies (e.g. external refill equipment) are also disconnected from the automat.

Release the pressure of vacuum tank before maintenance.

7.2 After a power failure

The programmed parameters of the controller do not change after a power failure.



- Check the condition of the automat for integrity after a power failure.

7.3 Maintenance interval

Confirm maintenance in the service menu.

Interval	Component	Activity
Annually	ENA 7-30	Check leak tightness of joints, pumps and screw connections. If necessary, seal or tighten the screw connections.
Every year before the peak period	On-site dirt trap in the feed line Vent. device	Clean the guards Check the functions Vacuum test

7.4 Change the automat for water treatment

- Switch off water treatment in the hardware menu and change the module.
- Adjust the capacity in the parameter menu.
- Switch on "water treatment" in the hardware menu.



Installation and operating instructions

7.5 Error messages

Nr.	Message	Description	Reset	Possible cause	Troubleshooting
1	Pressure too low	System pressure too low, is outside working pressure range	B	<ul style="list-style-type: none"> Leakage Pressure-holding value wrongly set Wrong admission pressure Filling pressure too low 	<ul style="list-style-type: none"> Eliminate leakage Set correct pressure-holding value Increase filling pressure up to working pressure range
2	Pressure too high	System pressure too high, is outside working pressure range	B	<ul style="list-style-type: none"> Pump does not switch off Diaphragm expansion vessel too small/ wrong admission pressure Filling pressure too high 	<ul style="list-style-type: none"> Check control Check admission pressure / use larger diaphragm expansion vessel Lower filling pressure to working pressure range
3	Entrycap. too low	Litres counter does not supply water after make-up request	A	<ul style="list-style-type: none"> No pulses sent from litres counter, because: litres counter defective cable not connected setting value too low for litres counter response time 	<ul style="list-style-type: none"> Replace litres counter Connect cable Use higher setting value for response time
5	Cycle interval	Make-up cycle interval too short	A	<ul style="list-style-type: none"> Leakage in system False setting value 	<ul style="list-style-type: none"> Eliminate leakage
6	Nr. of cycles	Maximum number of cycles within time window exceeded	A	<ul style="list-style-type: none"> Leakage in system False setting value 	<ul style="list-style-type: none"> Eliminate leakage Program correct settings
7	Fill error	Filling without request (litres counter sends signal without filling)	A	<ul style="list-style-type: none"> Leakage Solenoid valve don't close/defective 	<ul style="list-style-type: none"> Eliminate leakage Replace solenoid valve
8	Quantity limit	Maximum quantity in a make-up cycle exceeded	A	<ul style="list-style-type: none"> Leakage Setting value for flow rate reduction too low 	<ul style="list-style-type: none"> Eliminate leakage Correct the setting value
9	Runtime protection	Maximum time of make-up cycle exceeded	A	<ul style="list-style-type: none"> Leakage Setting value for flow rate reduction too low Pump doesn't deliver 	<ul style="list-style-type: none"> Eliminate leakage Correct the setting value Deerate pump
10	Exchange module	Softening module exhausted	A	<ul style="list-style-type: none"> Module capacity (water treatment) exhausted 	<ul style="list-style-type: none"> Replace module
11	Low mA P-sensor	Interruption of current loop of pressure sensor	A	<ul style="list-style-type: none"> Sensor defective Terminal/cable defective 	<ul style="list-style-type: none"> Replace sensor Check/exchange terminal/ cabling
12	High mA P-sensor	Short-circuit in current loop of pressure sensor	A	<ul style="list-style-type: none"> Sensor defective Terminal/cable defective Short circuit 	<ul style="list-style-type: none"> Replace sensor Check/exchange terminal/ cabling
13	Vacuum error	3 times in succession insufficient vacuum for deaeration	A	<ul style="list-style-type: none"> Temperature in return branch higher than 70 °C Pump does not operate continuously Leakage in ENA 7-30 Vent. device doesn't close 	<ul style="list-style-type: none"> Take steps for ensuring return temperatures below 70°C! Replace pump Locate leakage in ENA 7-30 Clean or replace vent. Device
14	Level switch error	Low level	A	<ul style="list-style-type: none"> Vent. device defective Strainer / inlet protected Valves closed 	<ul style="list-style-type: none"> Clean or replace vent. Device Clean strainer Open valves
18	Next maintenance	Next maintenance due	A	<ul style="list-style-type: none"> Maintenance date reached 	<ul style="list-style-type: none"> Carry out maintenance and enter „Maintenance done“ (Service menu)
19	TP motor	Motor protection signal (bimetal contact of pump) is active (open)	A	<ul style="list-style-type: none"> Pump overheated 	<ul style="list-style-type: none"> Check temperatures Check free running pump
20	Voltage sensor	Sensor voltage too low	B	<ul style="list-style-type: none"> Printed circuit board defective 	<ul style="list-style-type: none"> Replace control unit
21	No date/time	RTC has no valid time information	A	<ul style="list-style-type: none"> Time setting has got lost after prolonged disconnection from power supply 	<ul style="list-style-type: none"> Enter time and date again
22	Flash error	Read error Flash	B	<ul style="list-style-type: none"> Hardware/software problem 	<ul style="list-style-type: none"> Get in contact with service department
23	Flash error	Write error Flash	B	<ul style="list-style-type: none"> Hardware/software problem 	<ul style="list-style-type: none"> Get in contact with service department
24	Flash error	Reprogramming error Flash	B	<ul style="list-style-type: none"> Hardware/software problem 	<ul style="list-style-type: none"> Get in contact with service department
25	Gas sensor defective	Gas sensor defective	A	<ul style="list-style-type: none"> Malfunctions in measuring signal, possible faulty cable connection to SCU 	<ul style="list-style-type: none"> Check connection to controller, Exchange sensor if necessary
26	Gas sensor, under-voltage	Signal during Measurement <4mA	A	<ul style="list-style-type: none"> Sensor not connected, cable damage 	
27	Gas sensor, overvoltage	Signal during Measurement >20mA	A	<ul style="list-style-type: none"> Short-circuit in cable, signal too large 	<ul style="list-style-type: none"> Test cable connections, test vent device, if necessary clean the filters
28	Recurring indication of gas value "0"	several successive small gas values during measurement	A	<ul style="list-style-type: none"> Vent blocked/not working correctly 	<ul style="list-style-type: none"> Check and clean vent device

A: Necessary, reset possible within normal use (control restarts after resetting).
 B: No duty, automatic reset within normal use.



Installation and operating instructions

8 Disposal



Comply with local legislations.

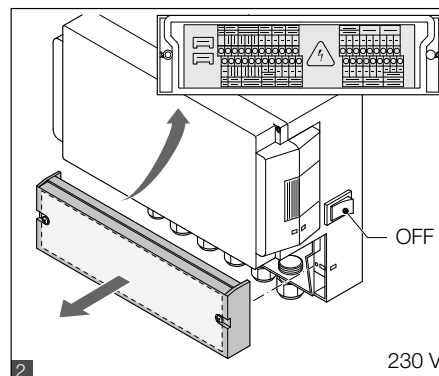
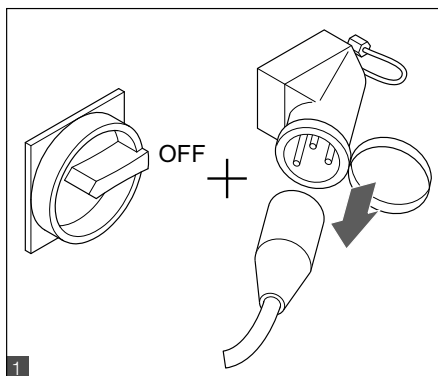

- Make sure the system power switch is OFF.
- Disconnect the power supply.

- Make sure the main power switch is OFF.
- Drain the water.



Installation and operating instructions

9 Technical specifications

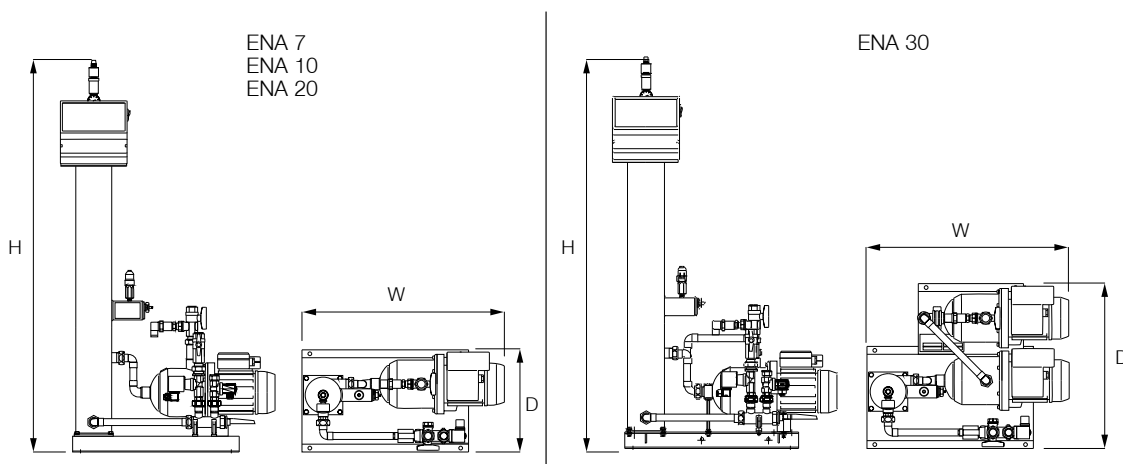

General		ENA 7	ENA 10	ENA 20	ENA 30
Article number	[-]	17070	17090	17091	17092
Volume	[l]	60	80	100	100
Working pressure	[bar]	0.8-2.7	0.8-3.5	2.0-4.5	3.0-8.0
Refill pressure	[bar]	2-8			
max. pressure	[bar]	8	8	8	10
Medium temperature	[°C]	0-70			
Top-up temperature	[°C]	0-30			
Noise level	[dB(A)]	approx. 55			
Electrical connection	[V]	230	230	230	230
Rating of the pump(s)	[kW]	1 x 0.62	1 x 1.1	1 x 1.51	2 x 1.1
Connections, dimensions, weights					
W x H x D	[mm]	728 x 1250 x 325	728 x 1250 x 325	776 x 1250 x 325	728 x 1250 x 525
Connection from system		Rp 3/4" (internal)			
Connection to system		Rp 3/4" (internal)			
Top-up connection		Rp 3/4" (internal)			
Weight	[kg]	38	40	45	60

Nominal diameter	Maximum line length system installation
DN20	10 m
DN25	20 m
DN32	30 m

9.1 Additional accessories

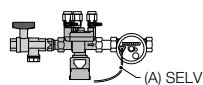

Pressurisation Unit type NFE 1... (3)

Feeds the machine with water. Make sure the water pressure is 2 to 8 bar. The level sensor and the make-up time control the unit.



Flamco

ENA 7-30 Appendix

Installation and operating instructions



© Flamco

www.flamcogroup.com

TP.03/24/09.EN

Edition 2009 / EXP

20



**Installation and
operating instructions
appendix**

Contents		Page
1.	Commissioning	22
1.1.	Commissioning ENA 7-30	22
1.2.	Parameterisation for commissioning	22
2.	Items of the hardware and parameter menu	23
2.1.	Operating modes	23
2.1.1.	Fast	23
2.1.2.	Normal	23
2.1.3.	Hand	23
2.2.	Control modes	23
2.2.1.	Level-controlled [%]	23
2.2.2.	Pressure-controlled [P]	23
2.2.3.	Filling off	23
2.3.	Monitoring	24
2.3.1.	Make-up quantity (monitoring)	24
2.3.2.	Pressure monitoring	24
2.3.3.	Monitoring of quantity of water to be treated	24
3.	Menu descriptions	25
3.1.	Hardware menu	25
3.2.	Parameter menu	26
3.3.	Service menu	27
4.	Examples	28
4.1.	ENA 7-30 in a heating system with return flow	28
4.2.	ENA 7-30 in a heating system without return flow	28



1 Commissioning

1.1 Commissioning ENA 7-30

Before commissioning make sure that the unit and its items of equipment are in conformation with the regulations that apply at the place of erection and in respect of the field of application. The party erection and operating the unit will be responsible for making the checks and for carrying out commissioning.

For commissioning, the hydraulic and electric connections must be in place, and the shut-off devices open.

1.2 Parameterisation for commissioning

The ENA 7-30 comes with a pre-parameterized control. As this control offers a wide range of possibilities, you will have to set operating parameters so that they will be adapted to the concrete operating conditions of your heating/cooling system.

When the control is switched on, first 'ENA 7-30' and after that the start screen appears on the display. Now it is possible to make a selection by turning and pressing the control knob.

Turn and press the control knob (on System, displayed against a black background) to get to the Selection menu. Select 'Entries' (code 000001) to get to the Equipment, Parameter and Service menus for carrying out parameterization. Set up the control point by point – refer to the sections with explanations on the Hardware, Parameter and Service menu (ENA 7-30 – Installation and operating instructions).

Select 'Back' to return to or to complete menu items. For completely exiting submenus, you can also hold the control knob in the pressed state, causing the control to invoke the Process screen/START menu.

On completing the parameterization of the control, confirm/press Start to get to the Process screen. The ENA 7, 10, 20, or 30 will then commence its operation.



2 Items of the hardware and parameter menu

2.1 Operating modes

The operator can operate the system in the fast and normal de-aeration mode. Service personnel have also access to hand mode, and can carry out a leakage test. This leakage (vacuum) test can also be used to test the ability to operate the pump.

2.1.1 Fast/Turbo

Pump running (with formation of a vacuum) takes place alternately with the evacuation interval until the period of time selected for the fast mode expires. Then, the control automatically changes to normal mode.

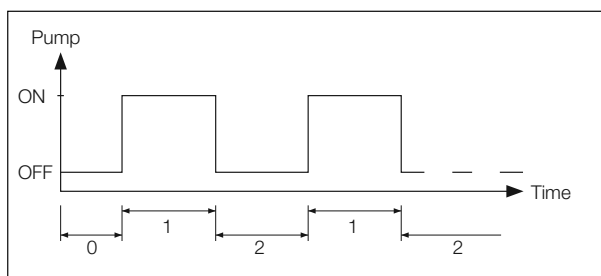

- 0 Start delay
- 1 Pump run
- 2 Deaeration time

2.1.2 Normal

The normal de-aeration mode is only automatically interrupted by a pause to avoid possible de-aeration noise during the night.

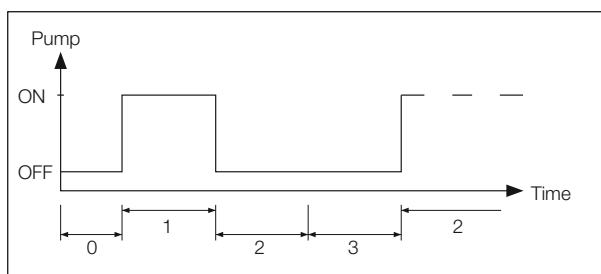

- 0 Start delay
- 1 Pump run
- 2 Deaeration time
- 3 Pause duration

2.1.3 Hand

The hand mode is intended exclusively for maintenance purposes, i.e. for checking the operation of the pump and of the solenoid valve. The plant operator cannot access this mode.

- **Vacuum test**

Activation of this mode first causes the system port (at outlet of the system return line) to be closed. The pump then generates a vacuum within 5 seconds. This vacuum must be maintained for about 100 seconds to allow the user to determine that the tank is tight, following which the test is successfully completed. This test is normally carried out prior to commissioning of the system and after maintenance of the system.

2.2 Control modes

2.2.1 Level-controlled [%]

Control takes place via an external floating signal or a non-floating signal (230 V). It depends on the used pressure-holding control and whether a pump-controlled or compressor-controlled diaphragm expansion vessel is used. When the signal is applied, the pump switches on. The filling operation takes place until the level set on the control of the expansion vessel is reached.

2.2.2 Pressure-controlled [P]

Control takes place via the pressure sensor that is integrated in the module. When the system pressure has dropped to the activation pressure 'Fill command on', the pump switches on and operates until 'Fill command off' is reached.

In both control modes, the running time and filling quantities (if the system is equipped with a pulse water meter) are monitored. In addition to this, the pressure in the system is monitored. If the system pressure falls or rises beyond the working pressure range, an error message appears. The system activates degassing and filling until the pressure is back in the working range.

2.2.3 Filling off

The ENA 7-30 unit operates solely as an automatic de-aeration unit.



2.3 Monitoring

It is the primary purpose of the monitoring functions to detect errors in the system at an early point of time and to protect the system components to the largest possible extent by means of appropriate signals or by automatically shutting down the system. They are particularly intended for detecting leakages at an early stage and to limit leakages.

2.3.1 Make-up quantity (monitoring)

The operator can freely parameterise the make-up quantity. If the conditions described below are not satisfied, the system will indicate an error; the floating error contact will be opened until the error is manually acknowledged.

- The actual run time must not exceed a maximum time per cycle.
- The minimum interval between two cycles (pause) must not be shorter than the time programmed.
- The maximum number of cycles per time window must not exceed the number programmed in the run time window (e.g., not more than 3 cycles in the last 8 hours.)

If a litres counter (IWZ in NFE1.2/2.2) is connected and activated, the operator can monitor a maximum filling quantity per cycle instead of the maximum filling time per cycle

2.3.2 Pressure monitoring

The maximum allowable pressure and level should not be exceeded. Therefore, pressure deviations are signalled.

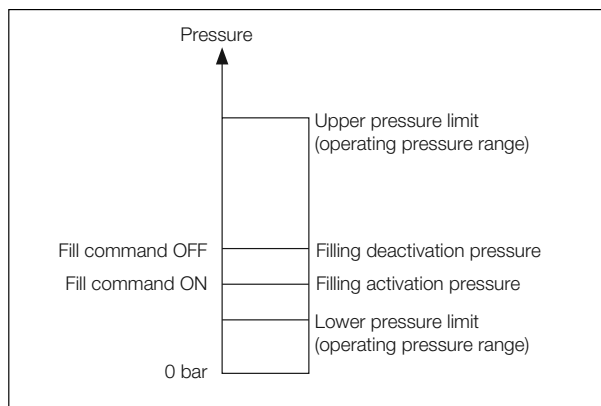

pMIN and pMAX are set on the working pressure limits and are not adjustable by the operator. pON and pOFF are adjustable within these limits.

2.3.3 Monitoring of quantity of water to be treated

If a water treatment module has been installed and the pulse water meter has been set to ON, the residual water quantity can be read at the lower right in the process menu. I.e.: if the residual water quantity has been correctly entered in the parameter menu 'Water treatment prior to commissioning'. If the quantity is zero litres, the centralised fault alarm will be tripped (if activated), and an error message will be initiated. Negative values mean that the permissible treated quantity (capacity) in litres has been exceeded. The ENA 7-30 continues to operate in such a case.



3 Menu descriptions

3.1 Hardware menu

ID number

Can be parameterised only by the manufacturer and service personnel.

Language

The operator can choose between 17 languages. German (G2_1) is the default setting on delivery.

Litres counter (IWZ)

Set this item to ON only if a pulse water meter (litres counter) is used. The pulse water meter can be used for directly controlling and monitoring the supplied make-up water. The default setting is OFF.

Water treatment

If a water treatment module has been integrated in the make-up water branch and the litres counter has been set to ON, the residual water quantity that can be read in litres in the process menu. When a quantity of zero litres is reached, the centralised fault alarm is tripped, and an error message will be displayed. Negative values mean that the allowable treatment quantity (capacity) has been exceeded. The make-up unit continues to operate even if the centralised fault alarm has been tripped. The operator must activate the water treatment function.

Control mode

(Make-up mode) The operator can operate the system in a level-controlled (controlled from an external pressure-holding control) mode or in a pressure-controlled mode (default setting for normal gas-cushioned diaphragm expansion vessel). The operator also can deactivate the make-up function.

Operating mode

The unit is shipped from the factory with the fast mode activated. Upon expiry of the fast interval, the unit automatically switches to normal. However, the operator can change the operating mode at any time. The hand mode can be activated for servicing purposes only. Vacuum test serves for ensuring the de-aerating operation and for checking leakages in the system. This function must be used when the unit is commissioned and each time the unit is put back into service after maintenance. After the test has been completed, the unit must be switched back to the fast mode.

Sensor / Motor protection

Already been parameterised. Factory setting.

Common failure

If set to ON (item ticked), the common failure will be tripped upon the activation of the respective error message. The default setting is ON. It is possible to deactivate the following centralised fault alarms: 'Exchange module' and 'Next maintenance'.

- Exchange module: the water treatment capacity is exhausted. If it is set to ON, a centralised fault alarm will be tripped. The unit continues to operate. If set to OFF, no centralised fault alarm will be tripped.
- Next maintenance: maintenance date has been reached. If it is set to ON, the centralised fault alarm will be tripped and the unit continues to operate. If set to OFF, no centralised fault alarm will be tripped.



3.2 Parameter menu

Item	Factory setting
Duration of turbo	
- Remaining fast run time up to automatic change to normal mode	10 hours
Pause normal degaz	
- Duration of pause between end of evacuation time and beginning of pump run	15 minutes
- Pause ON (beginning of night pause)	06:00 pm
- Pause OFF (end of night pause)	08:00 am
Degassing	
- Pump run time	Pressure dependent [s]
- De-aeration time	60 seconds
System pressure	
- pON: depending on the system type	ENA 7 -> 1.5 bar ENA 10 -> 1.5 bar ENA 20 -> 3.0 bar ENA 30 -> 5.0 bar
- pOFF: depending on the system type	ENA 7 -> 2.0 bar ENA 10 -> 2.0 bar ENA 20 -> 4.0 bar ENA 30 -> 6.0 bar
- Lower pressure limit (lower working pressure limit)	Depending on the system type
- Upper pressure limit (upper working pressure limit)	Depending on the system type
- Special system pressure (irrelevant for the operator)	Factory setting
Litres counter	
- Litre/pulse: pulse water meter (can be set only by service personnel)	10 litre/pulse
- Error litres counter: monitoring of delay of cycle of litres counter	40 minutes
Water treatment	
- Treatment capacity in case of integrated water softening module	100 litres

Filling quantity:

Based on a continually referenced preceding period of time (time window), the unit allows using a certain number of filling cycles that are separated by pauses from one another. Cycles, pauses and time windows (time spending) can be freely parameterised.

Example: (default setting)

In the last 480 minutes (time spending) the make-up water quantity per cycle must not exceed 50 litres. Moreover, it is not permissible to supply this quantity during this time more than three times, and the pauses between the cycles must be 5 minutes at a minimum.

Item	Factory setting
Max quantity/filling	
- Maximum allowable quantity per cycle (also per cycle) with integrated and configured pulse water meter. See section Monitoring: make-up quantity	150 litres
Max time/filling	
- Maximum allowable make-up time per cycle (also per cycle). See section Monitoring: monitoring of run time	20 minutes
Min. interval betw. 2 cycles	
- Minimum interval between two cycles (pause)	5.0 minutes
Max cycles/time spend	
- Maximum number of cycles per time window	3
Time spending	
- Size of time window	480 minutes

Note that the values in the filling quantity menu are interdependent. Therefore, it may be necessary to first parameterise another value before the actual value becomes accessible within the intended limits. Similarly, setting ranges may be limited by the dependencies. It is advisable, for instance, to first parameterise a sufficiently sized time window before defining the pauses and the number and length of cycles.



Item	Factory setting
Time and date	Operator task
- Summer time on: starting month (summer time ON is 00 for regions without change between times)	03
- Summer time off: ending month (summer time OFF=00 for regions without change between times)	10
- Maintenance gap: maintenance interval 0 .. 800 days	365 days
- Pressure sensor min.value	0.0 bar
- Pressure sensor max.value	10.0 bar

3.3 Service menu

Project number

Factory settings; not be programmed by the operator.

Software version

Readable entry made by manufacturer.

Start

Enter the time and date of the start (traceability) by pressing Start. Before pressing, the date and time must have been correctly set.

Maintenance

The date of the next maintenance is indicated in parentheses. When this time is reached, the centralised fault alarm is optionally tripped, and a fault message is displayed to remind the operator. If it is acknowledged, it will be displayed again after seven days unless 'Maintenance done' has been pressed, thus indicating that the maintenance has already been carried out. The time and date of the last maintenance as well as the code level are indicated in the upper two lines.

Error list

Shows the last acknowledged 250 errors together with time and date.

Value statistics

Display of various statistic data.

Refill statistics

Display of the last 200 make-up operations together with date, time and duration of the make-up operations and the number of litres supplied (if a pulse water meter is used).

The number of supplied litres displayed may be zero, although water has been fed into the system, if the make-up quantity was smaller than the pulse rate of the pulse water meter. Similarly, the actual quantity of water supplied may be smaller than the value registered by the pulse water meter.

Change entry code

Change to another access code. For the operator, only code 000001 is possible and required.

4 Examples

4.1 ENA 7-30 with NFE1.1 and a diaphragm expansion vessel in a heating system

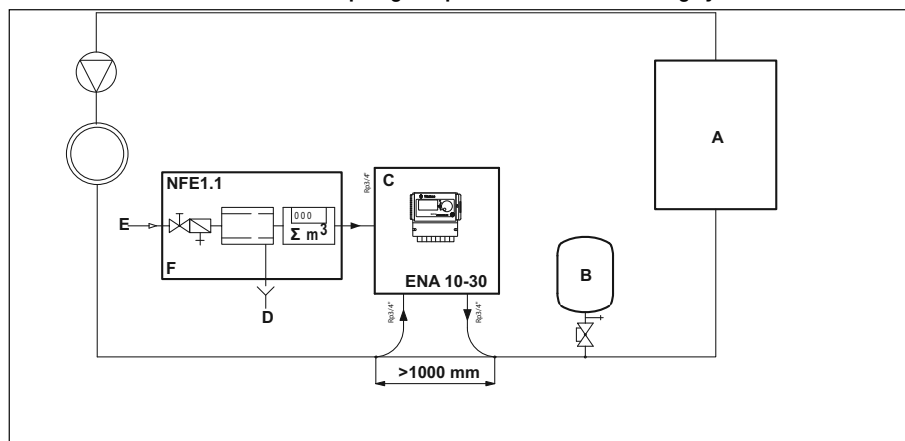

A	Heater
B	Diaphragm expansion vessel
C	ENA 7-30
D	Waste water (Drain)
E	Make-up water inlet
F	NFE 1.1

**Do not use nominal bores smaller than indicated for the lengths of the lines concerned!
The lines should be as short as possible!**

DN20 < 10 m
DN25 < 20 m
DN32 < 30 m

4.2 ENA 7-30 with NFE1.2 and a compressor controlled pressure level in a heating system

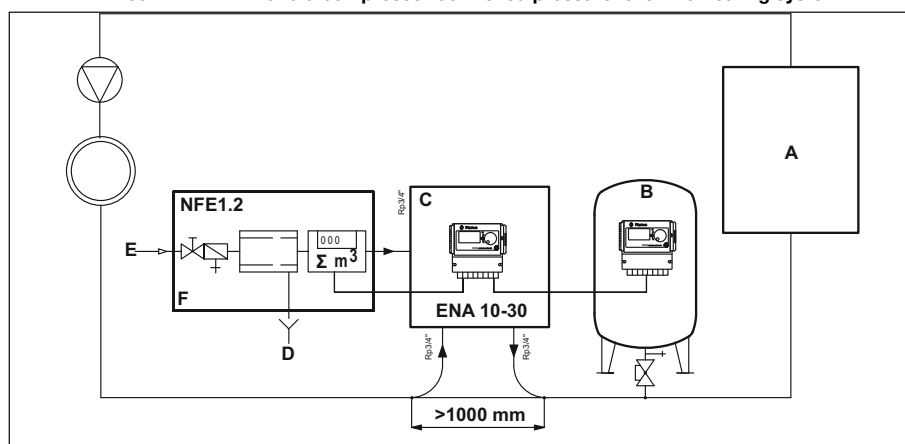

A	Heater
B	Diaphragm expansion vessel
C	ENA 7-30
D	Waste water (Drain)
E	Make-up water inlet
F	NFE 1.2

**Do not use nominal bores smaller than indicated for the lengths of the lines concerned!
The lines should be as short as possible!**

DN20 < 10 m
DN25 < 20 m
DN32 < 30 m